



RISHI SHIPPING



"RISHI HOUSE"

Rishi House", Plot No. 113-116, Ward - 6, Industrial Area, Gandhidham - 370 201, Kutch, Guj. (India)
Ph No. : (O) 91-2836- 257347, Mob: 98252 377259 Fax : 91-2836- 257343

e-mail : bkmansukhani@rishishipping.com, manoj_mansukhani@rishishipping.com
rishi_mansukhani@rishishipping.com, neetu_mansukhani@rishishipping.com
website : www.rishishipping.com

Experts in Handling of bulk Export cargo like SBM, RSM, WHEAT, RICE, SALT, VARLEY, SUGAR, MILL SCALE & IMPORTED FERTILISER, COAL, LOGS, STEEL COILS, SCRAP, IRON ORE, ROCK PHOSPHATE.

Providing complete Logistics Solutions in Containerized Import & Export Cargo.

Also Handling CAPE size vessels of Coal & Fertilisers with a fleet comprising :- 2 Floating Cranes, 7 Liebherr bulk Cargo handling machines, 26 Barges carrying capacity of 4600 mts., Excavators, Dumpers & Tailors



IFFCO NANO UREA LIQUID

World's First Nano Fertiliser

- Enhances Plant Growth
- Environment Friendly
- Reduces Input Cost to Farmers
- Improves Soil Quality

500 ml bottle at ₹240/-



INDIAN FARMERS FERTILISER COOPERATIVE LIMITED
IFFCO Sadan, C-1 District Centre, Saket Place, New Delhi - 110017, INDIA
Phones : 91-11-26510001, 91-11-42592626. Website : www.iffco.coop

PURBAPALLI DURGOTSAV
34th year of Celebration



वर्गह्या २०२२

Purbapalli Durgabari Samiti

(Regn. No. HR/018/2014/01465) : H.No. 876, Durga Niwas, Sector 14, Gurgaon, Haryana, Pin 122001. Email: purbapalli.durgabari@gmail.com; www.purbapalli.org; www.facebook.com/purbapalli

With Best Compliments from

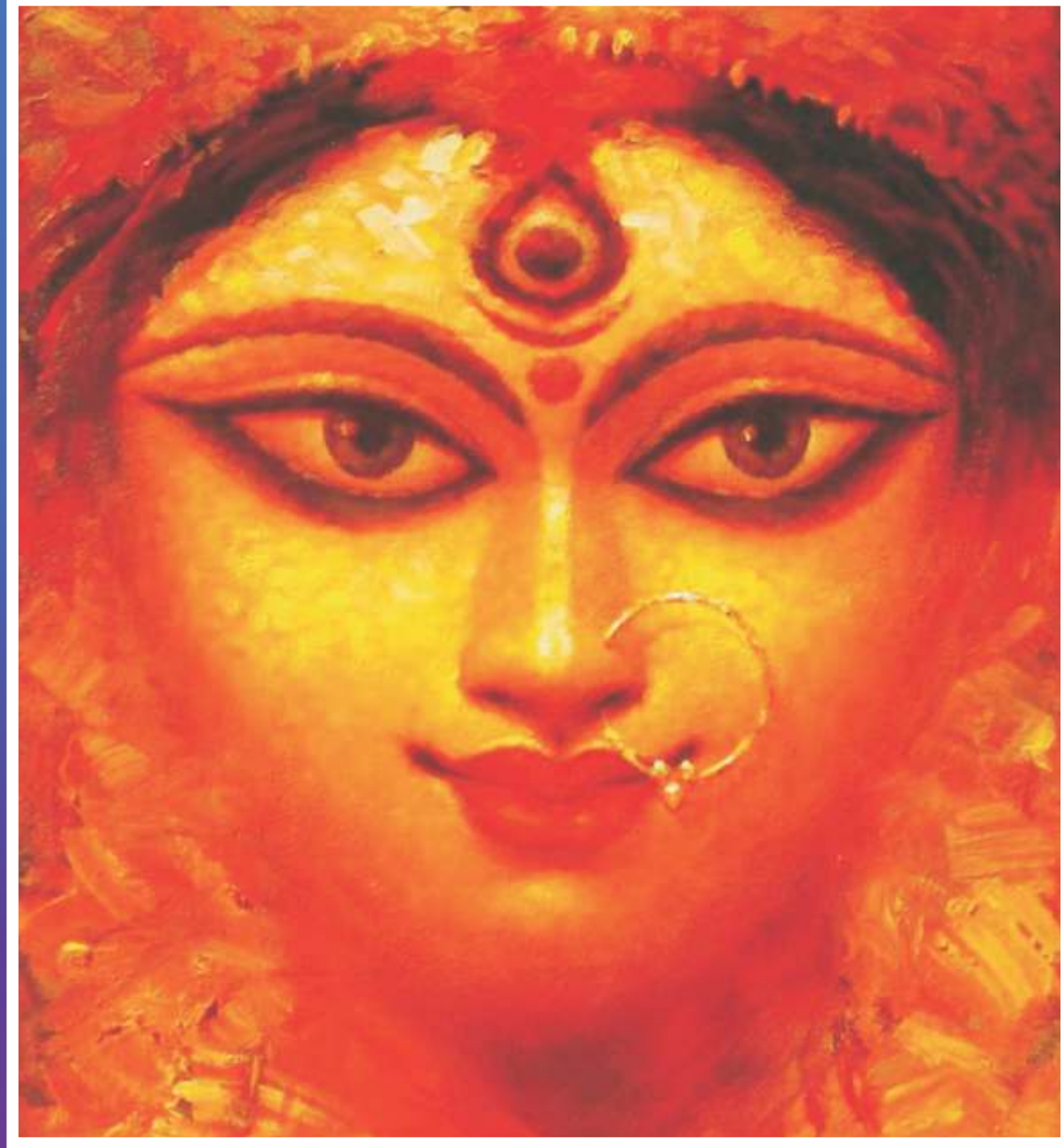

**FULCRUM ALM
SOLUTIONS PVT. LTD.**

Happy Dussehra

**A time for celebration, A time for victory of good over bad,
A time when world see the example of power of good.
Let us continue the same "true" spirit. Blessing of Dussehra.**



With Best Wishes
AFCONS Infrastructure Ltd.
Pandoh Bypass Takoli Project
Vill - Shala Nal, PO - Thalaut,
Tehsil - Aut, Distt. Mandi,
H.P.



IFFCO NANO UREA LIQUID



इफको नैनो यूरिया तरल

www.nanoured.in

Order Now: www.iffcobazar.in



*"Ya Devi Sarvabhuteshu
Shaktirupena sangsthita*

*Namasteshyoyee Namasteshyoyee
Namasteshyoyee Namoh namahah"*

ARGHYA-2022

34th Anniversary Edition

Compiled By : SOUVENIR COMMITTEE

ADDRESS FOR COMMUNICATION :

PURBAPALLI DURGABARI SAMITI
Durga Niwas, House No. 876, Sector 14,
GURGAON-122001



PURBAPALLI DURGOTSAV



|| GITA - SAAR ||

*Why do you worry in vain?
Why do fear?
Who can kill you?*

*A soul never dies or takes a birth.
"Whatever happened - happened for good;
Whatever is happening - is happening for good;
Whatever will happen - will happen for good.
Do not worry about the past or the future
-live in the present.*

*"What have you lost that makes you cry?
What did you bring to this earth that you have lost?
You came empty handed and will die empty handed.
Today what is yours - yesterday was someone else's
And tomorrow will belong to someone else.
Whatever materialistic pleasures you
have caused you sufferings.*

*Change is a rule of the world
In a second you become a rich and
in a second you become poor.
This is a mine, that is yours -
Remove such feelings and you will be liked by everyone.*

*This body is not yours -
it is made of Fire, Water, Air, Earth & the Sky
your inner soul is constant.*

*You should dedicate yourself to the God.
He will free you of your fear, anger & sorrow.*

*Whatever you do; dedicate it to God.
By doing so you will get the pleasure of becoming free from
Life-death cycle.*

**We take this opportunity to thank all those who helped us directly or indirectly in publishing this year's
'Arghya - Souvenir-2022' - the patrons, the advertisers, the printer and others.
Any error or omission is deeply regretted.**

- Souvenir Commitee



Contents

Gita Saar	1
Message	3
Committee Members	7
Sub-Committee Members	8
Glimpses of Durgotsav	10
Events Programme Schedules	
- Puja	25
- Sports	27
- Sanskriti	29
Cultural Programme Synopsis	41
Literary	73
Media Coverage & Activities	116
Member's Directory	120



Smt. Droupadi Murmu
President of India



राष्ट्रपति
भारत गणतंत्र
PRESIDENT
REPUBLIC OF INDIA

Message

On the auspicious occasion of Durga Puja, I extend my warm greetings and best wishes to all the fellow citizens living in India and abroad.

Maa Durga is Shakti Swarupa and this festival is an opportunity to show respect towards women power. A society where women empowerment is encouraged at every level in a true sense, can be considered to be a modern, developed and just society. The nine forms of Goddess *Durga* symbolize the infinite power of the mother nature.

I wish the spirit of unity and fraternity is strengthened in our society through the festival of Durga Puja. Let us build a society where women are respected more and more and they are able to contribute equally in the process of nation building.

I pray to the *Jagat Janani Maa Durga* that she bestows her blessings upon all of us and all our countrymen may lead a life of happiness and prosperity.

(Droupadi Murmu)

New Delhi
September 26, 2022



श्रीमति द्रौपदी मुर्मु
राष्ट्रपति भारत



राष्ट्रपति
भारत गणतंत्र
PRESIDENT
REPUBLIC OF INDIA

संदेश

दुर्गा पूजा के पावन अवसर पर, मैं, भारत और विदेश में रहे सभी देशवासियों को हार्दिक बधाई और शुभकामनाएं देती हूँ।

माँ दुर्गा शक्ति स्वरूपा हैं और इनकी पूजा नारी-शक्ति के प्रति सम्मान प्रदर्शित करने का अवसर भी है। सही अर्थों में उसी समाज को आधुनिक, विकसित और न्यायपूर्ण माना जा सकता है, जहां हर स्तर पर नारी सशक्तीकरण का वातावरण हो। देवी दुर्गा के नौ रूप, प्रकृति की असीम शक्ति का प्रतीक हैं।

मेरी कामना है कि दुर्गा पूजा के माध्यम से हमारे समाज में एकता और भाईचारे की भावना सुदृढ़ हो। हम एक ऐसे समाज का निर्माण करें जिसमें महिलाओं का और अधिक सम्मान हो और वे राष्ट्र निर्माण में समान रूप से योगदान करने में सक्षम हों।

जगत जननी माँ दुर्गा से मेरी प्रार्थना है कि उनकी कृपा हम सभी पर बनी रहे और सभी देशवासी खुशहाली और समृद्धि का जीवन जीते रहें।

द्रौपदी

(द्रौपदी मुर्मु)

नई दिल्ली
सितम्बर 26, 2022

সভাপতির কলমে

"আমরা বেঁধেছি কাশের গুচ্ছ,
আমরা গেঁথেছি শেফালী মালা
নবীন ধানের মঞ্জরী দিয়ে
সাজিয়ে এনেছি ডালা।
এসো গো শারদলক্ষ্মী
তোমার শুভ্রমেঘের রথে,
এসো নির্মল নীল পথে"



সুধীবন্দ, আপনারা অবগত আছেন যে বিগত দুই বছর ধরে বিশ্বজোড়া ভুস্কিত ক'রা করোনা মহামারীর আবহে আমরা পূর্বপল্লী দুর্গাবাড়ী সমিতির দুর্গাপূজার আয়োজন সমস্ত রকমের কোভিড-বিধি মেনে একটি দূরবস্তী ফার্ম-হাউসে অনাড়ম্বরভাবে সম্পন্ন করতে বাধ্য হ'য়েছিলাম। কিন্তু এই বৎসরে পরিস্থিতি অনেকটা অনুকূল হওয়াতে আমরা মায়ের আরাধনা আমাদের পূর্বপল্লী দুর্গাবাড়ী সমিতির চিরাচরিত স্থানেই করতে পেরেছি যথোচিত উৎসবের পরিমণ্ডলে এবং কৃতজ্ঞতার সাথে জানাই সেটা সম্ভব হয়েছে অবশ্যই আপনাদের বহুমূল্য সহযোগিতায়।

মা দুর্গার এই আগমনকালে স্বত্বৎসরের অপেক্ষান্তে সকল মানুষের নির্বিশেষ মিলনের মহান উৎসবের ক্ষেত্র আজ প্রস্তুত যার অনন্য আনন্দধারা অন্য আর কোনো উৎসবে পরিলক্ষিত হ'য় না। দুর্গাপূজা সর্বজনীন - আমাদের দেশের বৈচিত্র্যের মধ্যে ঐক্যের বৈশিষ্ট্যের এক অনুপম নিদর্শন। নানাবিধ সমস্যায় জর্জরিত পৃথিবী'র এই সন্ধিক্ষণে মাতৃরূপা মহাশক্তির কাছে প্রার্থনা করি মহামারীর প্রকোপ কাটিয়ে প্রকৃতি আরও নির্মল হোক, অবসান হোক যতরকম দ্বন্দ-বিবাদ, হানাহানি - ঝাঙ্ক হোক আমাদের বিবেকবোধ, জাগ্রত হোক সকল শুভবুদ্ধির।

আজ্ঞে আপনাদের সকলের আন্তরিক প্রয়াস ও সর্বাঙ্গীন সহযোগিতায় আমাদের সবার প্রিয় পূর্বপল্লী দুর্গাবাড়ী সমিতি এই পূজাআয়োজনের ৩৪ তম বছরে পদার্পণ করলো। আপনাদের সকলের অবগতির জন্য জানাই যে পূর্বপল্লী দুর্গাবাড়ী সমিতির পরিচালনায় শ্রী শ্রী দুর্গাপূজা উপলক্ষে আগামী ১লা অক্টোবর থেকে ৫ই অক্টোবর পর্যন্ত এবং শ্রী শ্রী শ্যামাপূজা উপলক্ষে ২৪শে অক্টোবর মায়ের পূজার আয়োজন করা হয়েছে।

এই সম্মিলিত শারদীয় আনন্দোৎসবে সমিতির পক্ষ থেকে আপনাদের সকলকে জানাই সাদর আমন্ত্রণ এবং সেই সাথে সকল সুধীজনকে জানাই আন্তরিক ধন্যবাদ যাঁদের সর্বাঙ্গীন সহযোগিতা সমিতির এই প্রয়াসকে সাফল্যমণ্ডিত ক'রে তুলেছে।

পরিশেষে পরিচালনা সমিতির সকল সদস্যের তরফ থেকে আপনাদের জানাই শারদীয় আন্তরিক শুভেচ্ছা ও অভিনন্দন।

ধন্যবাদান্তে,

অরবিন্দ রায়

Message from General Secretary

It gives me great pleasure to welcome you all to Purbapalli Durgabari Samiti's 34th Durga Puja celebrations. A small group of people in Gurgaon came together back in 1989 to give birth to this Institution that Purbapalli is today. I would start by extending my gratitude to the founding members of Purbapalli for your constant and unconditional support, blessing and guidance. The essence of Purbapalli Durgabari Samiti is very simple, i.e. to continue with the rich heritage, customs and traditions of Bengalis despite living away from Bengal. We have always striven to bring in a part of Bengal in our daily lives and fill in joy and happiness in the lives of all who are associated with us. The enthusiasm, sentiment, and pride that defined the very first celebrations continue to be built upon in every year's celebrations. More and more visitors from all over Gurgaon join us to help make these celebrations a grand success.

As we at Purbapalli look forward to organise the Durga Puja for the 34th consecutive year, we wait with bated breath to have the time of the life while being part of the festivities. This year its all the more special as after two years of Covid-19 Pandemic and restrictions regarding the same, we are going to conduct our Puja at our home ground at Sector 15-II Community Centre, Gurgaon with the usual zeal and enthusiasm with which we have conducted Durga Puja for past few years. We are also looking forward to the live cultural performances on stage by our very talented members after a gap of two years.

I want to express my gratitude in particular to our donors, sponsors and advertisers who have made generous contributions to our organisation during these difficult times enabling us successfully conduct the puja even when economic conditions were probably not conducive due to pandemic.

I am grateful to all committee conveners and members for their relentless support and cooperation throughout the year. I encourage new members to come forward and support whole heartedly. New faces are always welcome, as it is an opportunity for new ideas, new vision and new thoughts.

I wish to all the members, their family and all those who are attending the festivities to have a great time. A very Happy Durga Puja to all of you.

May Maa Durga shower her blessings and usher in greater peace and prosperity.

Best regards,

Mihir Karmakar

General Secretary

PURBAPALLI COMMITTEE MEMBERS (2022-23)

STEERING COMMITTEE

Smt.Chhandita Warkare
Shri D Bhattacharya
Shri Pradyut Banerjee

PRESIDENT

Shri Arabinda Roy

VICE PRESIDENT

Shri Aniruddh Nandi

EXECUTIVE VICE PRESIDENT

Shri Malay Mondal
Shri Arup Basu
Shri Shubhankar Sanyal
Shri Alokenath De
Shri Sanjoy Dutta Gupta
Shri Shoubhik Sen
Shri Bhaskar De

GENERAL SECRETARY

Shri Mihir Karmakar

JOINT SECRETARY

Shri Rajarshi Sengupta

TREASURER

Shri Rajat Sengupta

JOINT TREASURERS

Shri Subho Sen

KALI PUJA & SARASWATI PUJA SECRETARY

Shri Swapan Kumar Biswas

PURBAPALLI SUB-COMMITTEE MEMBERS (2022-23)

PRATIMA

Conveners: Shri Shoubhik Sen
Shri Subhankar Sanyal
Members: Smt. Madhumita Nandi
Smt. Jayita Sen
Smt Shampa Sanyal

PUJA & PRASAD

Conveners: Shri Dheeman Chatterjee
Shri Rahul Ghosal
Shri Janmejaya Patra
Members: Smt. Manashi Chatterjee
Smt. Chhanda Warkare
Smt. Jui Sengupta
Smt. Anindita Banerjee
Shri Shoubhik Sen
Shri Tanmoy Sengupta
Shri Bhaskar De
Shri Abhijit Chatterjee

PANDAL

Conveners: Shri Tapas Majumder
Shri Chinmoy Roy
Members: Shri Shoubhik Sen
Shri Malay Mondal
Shri Subho Sen
Shri Sandipan Mukherjee
Shri Gobindo Bhowal
Shri Satyajit Ganguly
Shri Saurabh Samaddar

DECORATION

Conveners: Shri Satyajit Ganguly
Shri Gobindo Bhowal
Members: Shri Shoubhik Sen
Shri Chinmoy Roy
Shri Tapash Majumder
Smt Madhumita Nandi
Smt Ruma Biswas
Smt Rupa Bhowal

SECURITY

Conveners: Shri Sandip Ghosh
Shri Abhishek Roy
Shri Rajib Dutta Majumder
Members: Shri Soumendu Banerjee
Shri Shibaji Mitra
Shri Anjan Ganguly
Shri Tapas Majumder
Shri Jayanta Ghosh
Shri Indradeep Banerjee

VENUE

Conveners: Shri Anjan Ganguly
Shri Shibaji Mitra
Members: Shri Subrata Ghosh
Shri Tanmoy Sengupta
Shri Sandip Ghosh
Shri Sudeep Bhattacharya
Shri Rajib Mondal

INSTALLATION & IMMERSION

Conveners: Shri Diptendu Mandal
Shri Somnath Chatterjee
Members: Shri Shibaji Mitra
Shri Sudip Bhattacharjee (Apex)
Shri Abhijit Ghosh
Shri Subho Sen
Shri Sumant Mukherjee
Shri Amulyakali Roy
Shri Nilanjan Ray

PUBLICATIONS

Conveners: Shri Arnab Das
Smt. Madhumita Nandi
Members: Shri Rajarshi Sengupta
Shri Subho Sen

CULTURAL

Conveners: Shri Arup Das
Shri Prashant Goswami
Members: Smt. Chhanda Warkare
Smt. Manashi Chatterjee
Shri Himadri Nayak
Shri Rajarshi Sengupta

STAGE MANAGEMENT

Conveners: Smt.Manashi Chatterjee
Shri Shailesh Bhartia

Members: Smt.Urmi Karmakar
Shri Chinmoy Roy
Shri Tapash Majumder
Shri Prashant Goswami
Shri Sanjoy Duttagupta
Shri Soumen Saha

SPORTS & ACTIVITY

Conveners: Smt.Souditi Das
Smt.Mili Majumder

Members: Shri Soumen Saha
Shri Prabuddha Kundu

BHOG & REFRESHMENT

Conveners: Shri Swapan Kr. Biswas
Shri Rajesh Kr. Sinha

Members: Shri Subho Sen
Shri Chinmoy Roy
Shri Sanjoy Duttagupta
Shri Rajib Dutta Majumder
Shri Soumen Saha
Shri Pritam Biswas
Shri Sanjay Dosajh

STALLS & BANNERS

Conveners: Shri Abhiroop Lahiri
Shri Arnab Bhattacharya

Members: Smt.Barnini Sen
Shri Rajarshi Sengupta
Shri Chiranjib Dhar
Shri Shoubhik Sen
Shri Niladripati Bhattacharjee

PUBLIC RELATIONS

Conveners: Shri Himadri Nayak
Shri Joyes Sarkar

Members: Smt.Preeti Duttagupta
Ms. Animita Mitra
Shri Rahul Ghosal
Shri Satyajit Ganguly
Shri Gobindo Bhowal

MEMBERSHIP

Conveners: Shri Sanjit Panda
Shri Pallab Roy

Members: Smt.Manashi Chatterjee
Smt.Barnini Sen
Shri Rajarshi Sengupta
Shri Subho Sen

ANANDAMELA

Conveners: Smt Barnini Sen
Smt Apala Guha

Members: Smt Suparna Dutta Majumder
Smt Piyali Sengupta

FUND RAISING

Conveners: Shri Rajarshi Sengupta
Shri Bhaskar De

Members: Shri Arnab Bhattacharjee
Shri Mainak Bhattacharyya
Shri Niladripati Bhattacharjee
Shri Nilanjan Ray
Shri Diptendu Mondol
Shri Prashant Goswami
Shri Sudeep Bhattacharya

SOCIAL RESPONSIBILITY

Conveners: Smt Urmi Karmakar
Smt.Jui Sengupta

Members: Smt.Manashi Chatterjee
Shri Prashant Goswami
Shri Rajesh Kr. Sinha

BANGLA CLASS

Shri Abhijit Ghosh
Smt Sampa Sanyal
Smt.Jui Sengupta

LIBRARY & OFFICE

Shri Abhijit Ghosh
Shri Sudeep Bhattacharya
Shri Prashant Goswami
Shri Subho Sen
Shri Rajarshi Sengupta
Shri Mihir Karmakar
Smt Manashi Chatterjee

Glimpses Purbapalli Durgotsav 2021

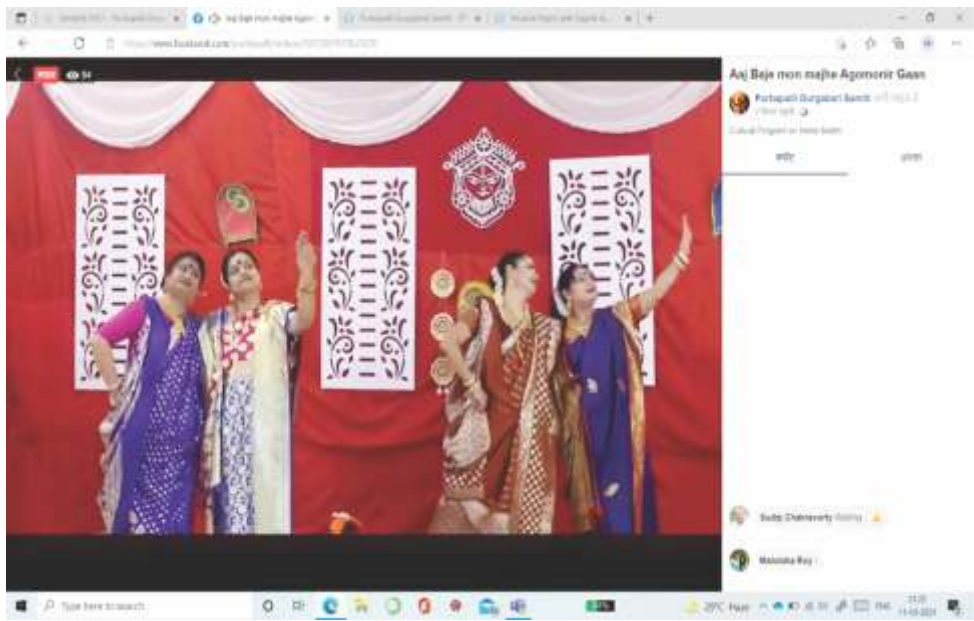

Glimpses Purbapalli Durgotsav 2021

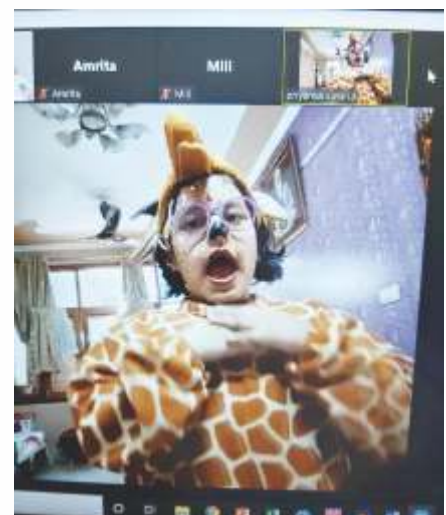

Glimpses Purbapalli Durgotsav 2021



Glimpses Purbapalli Durgotsav 2021



shree Shefali Swarajgi

Glimpses Purbapalli Durgotsav 2021

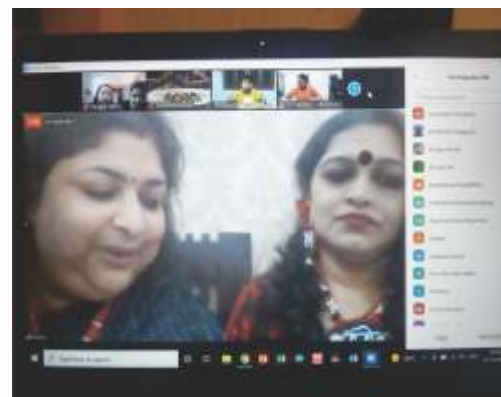

Glimpses Purbapalli Durgotsav 2021



Glimpses Purbapalli Durgotsav 2021



Glimpses Purbapalli Durgotsav 2021



With Best Compliment From



ACCORD CHARITABLE TRUST (RPG)

11 CAMAC Street Kolkata 700017

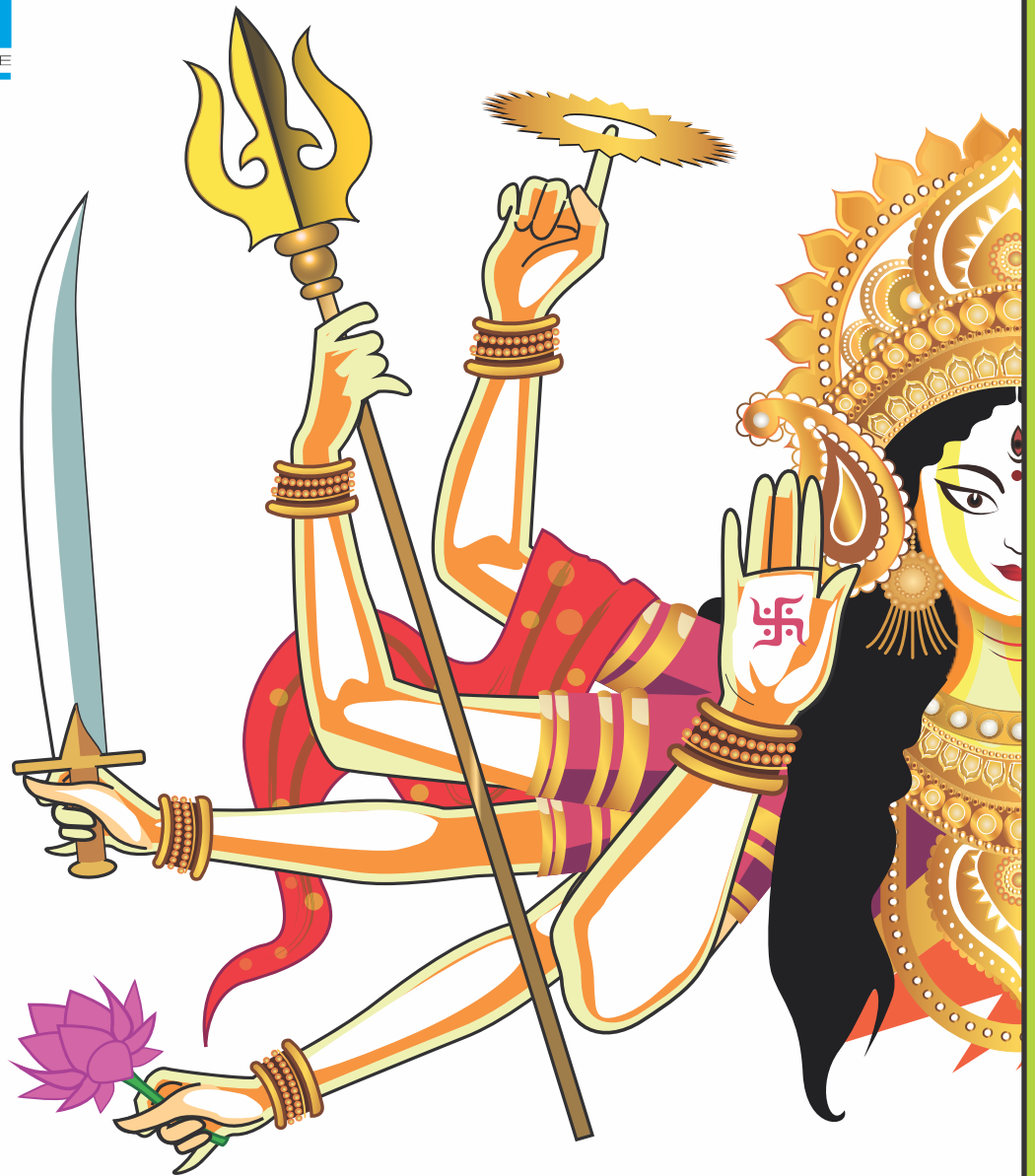

MAY HER BLESSINGS KEEP YOU SAFE.
COUNT ON US TO KEEP YOU FINANCIALLY SECURE.

OUR PRODUCTS: HEALTH INSURANCE | MOTOR INSURANCE | FIRE INSURANCE
PERSONAL ACCIDENT INSURANCE | MARINE INSURANCE | BANK LOCKER INSURANCE

IFFCO-Tokio General Insurance Company Limited

Corporate Office: IFFCO TOWER – II, Plot No. 3, Sector-29, Gurugram (Haryana) - 122001

IRDAI Regd. No.: 106 | CIN: U74899DL2000PLC107621 | UAN: ITGI/22-23/InstAdv/Generc English-01

For more details on risk factors, terms and conditions please read sales brochure carefully before concluding a sale. Insurance is the subject matter of solicitation. Terms and conditions apply.

Contact us (Toll-Free):

1800 103 5499

www.iffcotokio.co.in

With Best Compliment From



SRI BALAJI TRANSPORT

Bellary, Mandya, Mysore



In nature, there is *kindness*
In nature, there is *luxury*

We have only one home, one environment, one planet that so kindly looks after us, and that we must protect with equal kindness and love. In nature, there is kindness. In living, there is luxury. Eris Home was born out of a vision to transform the idea of modern-day luxury to one in unity with nature. True luxury, as an experience, ought to cause no harm in the process of its manufacturing and provide quality beyond measure in consumption. At Eris, we believe in sustainable and synergic living to the lives associated with us, from the silkworms to our dedicated team and clients. With cruelty-free at our core, we explored the use of Eri Silk, also known as 'Ahimsa Silk', which, unlike conventional sericulture practices, is consciously extracted from open-mouthed cocoons where silkworms have been allowed to hatch organically. The fine and durable yarns are then carefully spun at our sister concern in Assam, the largest producer of Eri Silk in India, which also shares our core values and beliefs by providing a livelihood for its predominantly female workforce.

ERIS HOME

A different kind of luxury

 ErisHome.official

 eris_home

 www.ErisHome.com

With Best Compliment From



**Harmony
Foundation (RPG)**

11 CAMAC Street Kolkata 700017

*With Best
Compliment From*



ADITYA EXPORTS

KAROL BAGH, NEW DELHI

With Best Compliment From



Shapoorji Pallonji Pandoh Takoli Highway Private Limited
Regd. Office: SP Centre, 41/44, Minoo Desai Marg, Colaba, Mumbai 400005, India.
(T) +91 22 67490000 (F) +91 22 67490017 website: www.sp-group.co.in

Shapoorji Pallonji Pandoh Takoli Highway Private Limited
Site Office: Jyoni Road, Bathli, VPO. Pandoh, P.O Pandoh,
Tehsil Sadar, Distt. Mandi-175124, Himachal Pradesh



**EVENTS
&
PROGRAMMES**



Durga Pujo 2022- Pujo Schedule
দূর্গা পূজো নিৰ্ঘন্ট - ২০২২
Gurugram, Haryana

PURBAPALLI
DURGOTSAV
Celebrating 34th Year

দেবীর গজে আগমন

Devil's Arrival on Elephant

দেবীর নৌকায় গমন

Devil's Departure on Boat

Maha Shashthi - মহাষষ্ঠী

1st October (Saturday) 14th Ashwin	8:00	Maha Shashthi Pujo Begins দেবীর ষষ্ঠাদি কল্পারস্ত ও ষষ্ঠী বিহিত পূজা প্রশস্ত	
	18:30	Bodhan Pujo / শ্রীশ্রী শারদীয়া দুর্গাদেবীর বোধন Invocation of Goddess / আমন্ত্রণ অধিবাস	

Maha Saptami - মহাসপ্তমী

2nd October (Sunday) 15th Ashwin	7:00	Maha Saptami Pujo Begins / দেবীর নব পত্রিকা প্রবেশ সপ্তমী বিহিত পূজা প্রশস্ত	
	10:00	Pushpanjali :: পুষ্পাঞ্জলি	
	18:30	Sandhya Aroti / সন্ধ্যা আরতি	

Maha Ashtami - মহাঅষ্টমী

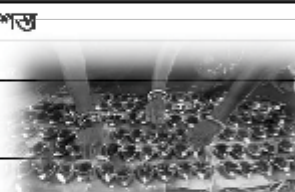
3rd October (Monday) 16th Ashwin	7:00	Maha Ashtami Puja Begins / দেবীর অষ্টমী বিহিত পূজা প্রশস্ত	
	10:00	Pushpanjali :: পুষ্পাঞ্জলি	
	15:36	Sondhi Pujo Starts / সন্ধি পূজার আরস্ত	
	16:24	Sondhi Pujo Concludes / সন্ধি পূজার সমাপন -	
	18:30	Sandhya Aroti / সন্ধ্যা আরতি	

Maha Navami - মহানবমী

4th October (Tuesday) 17th Ashwin	7:00	Maha Navami Pujo Begins / দেবীর নবমী বিহিত পূজা প্রশস্ত	
	10:00	Pushpanjali :: পুষ্পাঞ্জলি	
	18:30	Sandhya Aroti / সন্ধ্যা আরতি	

Bijoya Dashami - বিজয়া দশমী

5th October (Wednesday) 18th Ashwin	8:00	Vijaya Dashami Pujo / দশমী পূজো	
	9:00	Dorpon Bishorjon / দর্পন বিসর্জন	
	10:00	Mayer Boron / মায়ের বরণ	
	19:00	Shanti Jol	

Shree Shyama Pujo 2022- Pujo Schedule
শ্যামা পূজো নিৰ্ঘন্ট - ২০২২
Gurugram, Haryana

PURBAPALLI
DURGOTSAV
Celebrating 34th Year

24th October Monday 6th Kartik	22:00	Shree Shree Shyama Pujo Begins / শ্যামা পূজার আরস্ত	
25th October Tuesday 7th Kartik	1:00	Pushpanjali :: পুষ্পাঞ্জলি	
	3:00	Aroti / শ্যামা মায়ের আরতি	
	8:00	Dorpon Bishorjon / দর্পন বিসর্জন	

With Best Compliment From



NITIN KANSAL

SPORTS ACTIVITIES PROGRAMME SCHEDULE

PURBAPALLI DURGA PUJO 2022

1st oct 2022, saturday 11am:

Recitation competition for children

Group 1...below class 1(poem name: Aaw Billi)

Group 2...class 1 to class 3 (poem name: Khuki O kathbirali)

Group 3....class 4 to class 6 (poem name : Dustu)

Group 4...ladies and gents (poem name: Durgoti nashinir protti)

NOTE : for group 1,2,3 marks will be given on: memorization, expression, intonation.

For group 4 marks will be given on expression, intonation and throw of delivery) All poems are being attached with the mail, find your own poem accordingly from the attachments

12noon: Fashion show: Incredible Purbapallians

Theme : Go Ethnic

Category 1...single female walk on ramp/stage(25yrs and above)

Category 2...single male walk on ramp/stage(25yrs and above)

Category 3....couple walk(25yrs and above...choose your won partner , it can be random)

Participants can bring their own music in mobile which can be played through blue tooth speakers , else general music will be played by the committee

Judgement criteria:

1.creativity(keeping the theme in mind)

2.confidence

3.grooming and deportment(how you carry yourself on stage)

Last but not the least: its all entertainment, participate in large numbers for fun. Please register in advance by whatsapp to the mobile numbers given below for smooth running of the event

Mili Majumde 9899449036

Souditi Das 8076854187

2nd oct 2022, Sunday 11am :

Drawing competition for children

Group 1....below class 1(draw anything you like)

Group 2...class 1 to class 3(topic will be given on spot)

Group 3...class 4 to class 6 (topic will be given on spot)

Group 4 ...class 7 to class 10(making of Durga face with household grocery items like cereals, pulses, spices ,condiments etc.)

12noon : Quiz contest for ladies and gents in a team of 2 persons (conducted by Prabuddha Kundu)

Choose your own team mate and contact For registration

Mili Majumder 9899449036

Souditi Das 9818646290

*With Best Compliment
from*



GLOBAL ENTERPRISE, KOLKATA

11A, Earle Street, Maddox Square, Kolkata. Phone : +91 33 40062221

EXPORTERS OF AUTO COMPONENTS

**Major Brands : UNO MINDA, EXIDE, ASK, LUMAX, SPAL,
HERO CHAIN AND SPROCKETS, SWISS, HALONIX ETC.**

SANSKRITI - 2022

Day	Time	Programme	Program Coordinators
Panchami 30th September (Friday)	7:30 PM	Anandamela	Barnini Sen Apala Bhattacharya
	9:30 PM	Garba	Nilanjana Deb Burman
Sashti 1st October (Saturday)	7:30 PM	Agomoni: Namu Devi Durge	Barnini Sen
	8:30 PM	Children's Play Hing Ting Chhat	Abhijit Ghosh
	9:20 PM	Dance: Raboner Dwidha	Indrani Goswami
Saptami 2nd October (Sunday)	7:30 PM	External: Folk Music	Tanushree Dey
	9:00 PM	Dance: Nodi Tumi Kon Katha Kou	Souditi Das
	10:15 PM	Play Reading: Bhushondir Mathe	Sampa Sanyal
Ashtami 3rd October (Monday)	8:00 PM	Musical Orchestra: Celebrating Life	Sudeep Bhattacharyya
	9:20 PM	Ladies Play: Bheem Bodh	Indira Mitra
Navami 4th October (Tuesday)	12:30 PM	External: Magic Show	Magician Sabyasachi
	7:30 PM	External: Bangla Band Shahar	Anindya Bose
	9:50 PM	Play: Nilkontho	Jayita Sen

With Best Compliment From



SANDEEP SHARMA

With Best Compliment From



**CHERRY
INTERNATIONAL,
ARGENTINA**

With Best Compliment From



Mukesh Dubey

With Best Compliment From

Paudel
Enterprises

Authorised dealer in-



Paudel Niwas, Basuki Nagar Marga Koteswor-35, Kathmandu

Nepal Tel.: +977 15199088,5199444

Mobile No.: +977 9851231361 (Manoj),

9861598041/9861598042, 9861598043 (Rajiv)

E-mail: pou.rajan@gmail.com | Website: www.paudelenterprises.com

With Best Compliment From



Dinesh Arora

*With Best
Compliment From*



SATYADIP INTERNATIONAL
KATHMANDU, NEPAL

Our Mfg. Range of V-Belt Driven, Tapper Roller Bearing Type Lathe Machine.

SHREEKANT



Centre Height - 250 mm (10") to 610 mm (24")
Admit Between Centre - 550 mm to 4800 mm
Bed Length - 5'6" to 20'
Bed Width - 324 mm to 654 mm
Spindle Bore - 50 mm to 150 mm

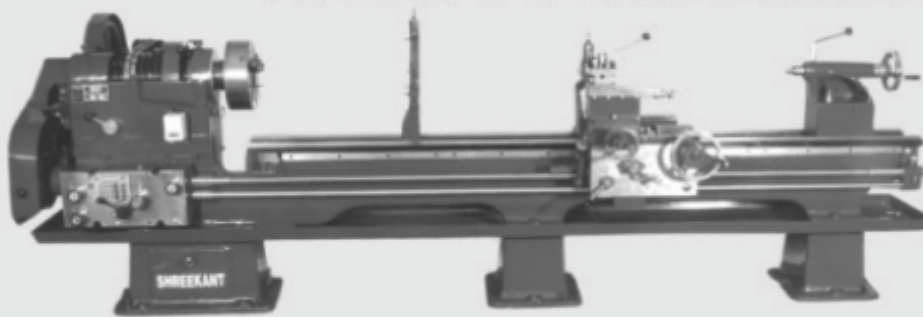
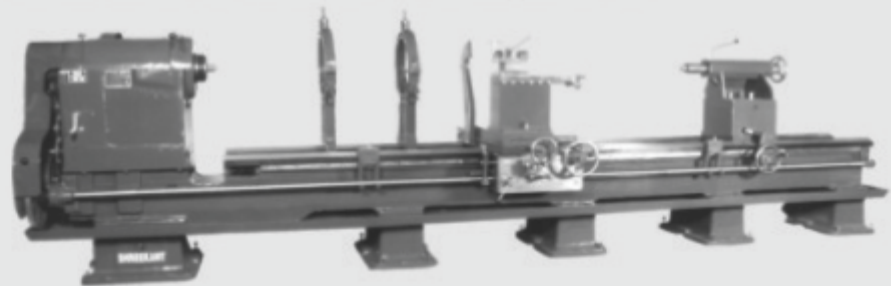
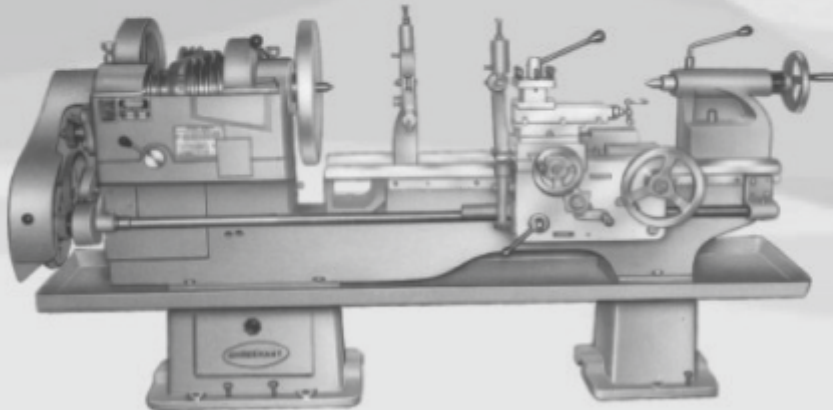

The Shreekant Machine Tools

MFG. OF LATHE MACHINE & V-GROOVE PULLEY

27/C, Bhaktinagar, Udyognagar, Rajkot-360002.

Tel.: (O) (0281) 2362774. Fax : 2371411. Mob : 098242 29211, 099240 41041

E-mail : shreemach@yahoo.com

*With Best Compliment
From*



**KHAN TRADING
DHAKA, BANGLADESH**

With Best Compliment From



SRI LAXMI TRADING COMPANY

Peddi Suresh Babu
Cell: 9849262870

#6-6-203, Nehru Gunj,
Karimnagar-505001, Telangana,
Ph.: 0878-2242870, 2247755
Email: sltcknr@gmail.com
peddisureshbabu15@gmail.com

With Best Compliment From



R. RAMULU H.&T. Contractor

D.No. 10-28, 1st Floor, VLC Complex,
Sagar Road, Miryalguda-508207
Nalgonda Dist. (Telangana)
Cell: 9866006959

With Best Compliment From



SOMANI BROTHERS

Distributors in: **FERTILIZERS & CHEMICALS**

15-7-578, Opp. Post Office,
Begum Bazar, Hyderabad-500 012
Tel.: 24745600, 24745262
Tele/Fax: 040-24742813,
Resi.: 24477846, 24743628
GodownL 23810728, 23810437
Email: mayursomancee@gmail.com

With Best Compliment From



Branch Office : Door No. 8-210/8 D No. 10/5, Nergamamba Estate Elhikuru Road. GUNTUR - 522003
Admin Office : #4, Block No. 38, Belaji House, Rc No. 84, Auto Nagar. HYDERABAD.
E-mail: manishkaran@belajifertilizer.com Cel : +91-8701586383
HYDERABAD | GUNTUR | BANGALORE | JALNA | VISHAKAPATNAM | KRISHNAGIRI





KEI

Wires & Cables



PROUDLY MAKING IN INDIA SINCE 1968

- Housewires (FR, FRLS, ZHFR) • LV Power & Control Cables • Instrumentation Cables
- HV Cables • Thermocouple Cables • Flexibles (Single & Multicore) • Winding Wires
- Solar Cables • Rubber Cables • Communication Cables • Co-Axial Cables
- EHV Cables up to 400 kV • Fire Survival Cables • Stainless Steel Wires

Registered and Corporate Office:

KEI Industries Limited: D-90, Okhla Industrial Area Phase-1, New Delhi-110020

• Tel: +91-11-26818840/8642/0242 • M: 7838090755

CIN No: L74899DL1992PLC051527



Scan Here

With Best Compliment From



Sri Tunga Transport
Shimoga

*With Best
Compliment From*



SHAIENDRA SINGH

B.Sc. Engg. (Electrical)
M. Tech (Engg. Systems)
M.: 9350865581

SHAIENDRA & DAS CO.

Electrical Engineers, Consultants, Govt. Licensed,
CPWD Registered Contractor & Supplier

Delhi Off.: 04, Plot No. B-12, Pandav Nagar, Delhi-110092
Email: shailendra.dasco@gmail.com

*With Best
Compliment From*



**FURNITURE | INTERIOR | TURNKEY PROJECT
RESIDENTIAL | CORPORATE | COMMERCIAL**

SHAFIKUR REHMAN

CREATIVE HEAD

+91 9891178618

+91 9311777521

C1/65, Opp. 110 Central Avenue Road
Gate No. 1, Sanik Farms Khanpur New Delhi 110062

Email: sameer@asinterior.design, asfurniture74@gmail.com

Web.: www.asinteriorgroup.com, www.asinteriorgroup.in, www.asinterior.design

*With Best Compliment
From*



AJAY KUMAR JAIN



— — — — —

**Cultural Programme
Synopsis**

— — — — —



Celebrating
34th
Year

THE WINNER OF
**BEST
PUJA**
2021

PURBAPALLI
DURGOTSAV



Bangla Band

Date: Tuesday, Oct 4th, 2022

Time: 07:30 PM

Celebrating
34th
Year

THE WINNER OF
**BEST
PUJA**
2021

PURBAPALLI
DURGOTSAV



Tanushree Dey
Bangla Folk

Date: Sunday, Oct 2nd 2022
Time: 7:30 PM

Celebrating
34th
Year

THE WINNER OF
**BEST
PUJA**
2021

 PURBAPALLI
DURGOTSAV

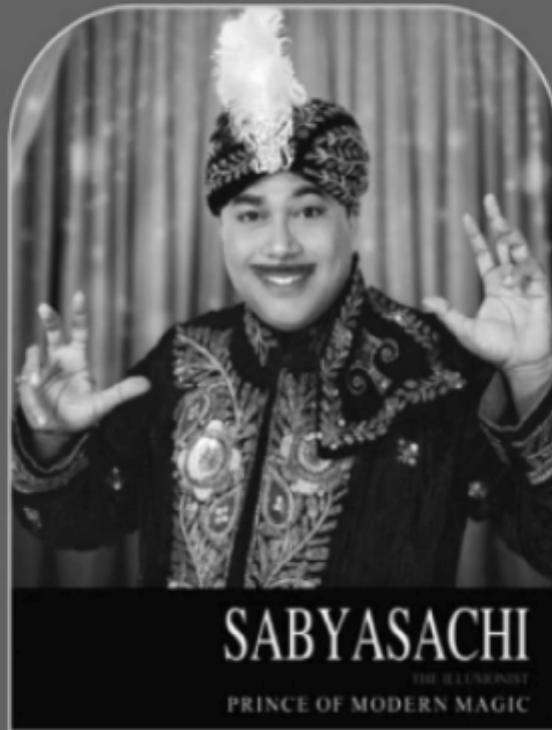

Magic Show

Date: Tuesday, Oct 4th, 2022

Time: 12:30PM

Musical-Celebrating Life

Songs and dances are the hidden languages of life, of the soul and the body and they are ways of celebrating life. They are ways to express what's in our heart and soul and ways to express various moments of our life, whether they sadden us or make us happy or the ones that we dearly cherish.

For two years in succession, the humanity was in the grip of an outbreak that was threatening people every day. Such was the scale and the magnitude of the outbreak that not only did it completely upset the life, push people indoors but took with itself millions of precious lives. Having triumphed over this and emerged out of two years of restrictions, the time has come to get back on the normal ways of leading life and importantly, to celebrate life.

A bouquet of timeless songs that express the thoughts around celebrating beautiful moments of life were presented in the musical program Celebrating Life. Homage was also paid to the leading lights of music world, the nightingale Lata Mangeshkar, Gitashree Sandhya Mukherjee, composer Bappi Lahiri, Padma Vibhushan Pandit Shiv Kumar Sharma and Bhupinder Singh that the world has lost this year, 2022 by way of songs that they sang or composed.

Day: Ashtami, 3rd Oct '22

Singers:

Amrita Purkayastha
Indrani Goswami
Surela Ganguly
Bhaskar De
Prashant Goswami
Rajib Dutta Majumdar
Sudip Chakraborty
Soumen Saha
Sudeep Bhattacharyya

Comperer:

Shreya Sen Khurana

Concept:

Sudeep Bhattacharyya





NILKONTHO

We pay our humble salutations to Soumitro Chatterjee, the doyen of Bengali film and theatre, through a bold attempt at staging his play Nilkontho. He played the title role for many shows on stage in Kolkata's iconic theatres, Biswaroopa and Rangmahal.

Though born in a well-to-do family, Nilkontho was just making his ends meet, when he was given shelter by A local zamindar. Slowly he became a favorite of both the zamindar and his wife through his simplicity. However, Nilkontho carries a secret within him through all these years. In an intoxicated moment he divulges the secret.

What happens next

CAST LIST

Nilkontho	Aniruddh Nandi
Rama	SHahana Dosajh
Dipu	Aurindam Mukherjee
Punyoshlok Babu	Shoubhik Sen
Alka	Sudeshna Gupta
Kailash Babu	Arup KUMAR Das
Nagendra	Arnab Das
Sukhomoy	SudIp BhattacharYya
Dashu	Pratim Brahmachari
Bindu	Urmi Karmakar
Sreemanto Babu	Santosh Sinha
Kader Miya	Tarun Sarkar
Sushil	Ayan Sarkar
Balika 1	Noyonika Bhattacharyya
Balika 2	Chayani Bandyopadhyay
Darshak Male	Saurabh Samaddar
Darshak Female	Sanjukta Bhattacharyya
Background Music	Bikram Gupta
Direction And Light	Jayita Sen
Produce By	Purbapalli Notto Company
Special Thanks To	Sreeparna Das, Ipshita Chakraborty Himadri Nayak



BHEEM BODH

Today's highly stressful lifestyle always looking for a bit of smile and a bit of humour. We had enough tensions in the last 3 years – i.e., 2020, 2021 and also in the earlier part of 2022. In view of that, we, the lady's group this year, present live, a short comedy play, written by Sri Narayan Gangopadhyay, titled - 'Bheem Bodh'.

Kalu Da, a crazy drama enthusiast, put his wholehearted efforts to stage a play, where all characters are moving on with their wishes and self-directions, making it a free for all. To induce extra comedy, we added extra flavour with the help of our most respected seniors.

I sincerely apologise to the original creator, for this modification. Needless to say and thanks, last but not least, heartfelt thanks to organisers/committee members and respected audience.

CONTRIBUTORS OF THE PLAY

Mashima	Smt. Rita Ghoshal
Chhanda	Smt. Chhandita Warkare
Shampa	Mrs. Shampa Bhattacharyya
Swapna	Mrs. Swapna Sanyal
Sumita	Smt. Rubi Maitra
Pande Boudi	Mrs. Neeru Kanwar Choudhuri
Bouma	Mrs. Supriya Chatterjee
Radha	Aparna Chatterjee
Kalu	Sampa Sanyal
Haradhan	Krishna Chatterjee
Nimai/Bheem	Animita Mitra
Peno/Duryodhan	Urmi Karmakar
Nikhil / Krishno	Barnini Sen
Bishe	Amrita Banerjee
Manu / Gandhari	Purobi Ghoshal
Dhritorastro	Sutapa Roy
Sanjay	Milli Majumder
Bibek 1	Ruma Biswas
Bibek 2	Sammridhhi Bhartiya
Prompters	Mausumi Ghosh, Suparna Dutta Majumder
Light and Sound	Taina Ghosh
Extra Support Hands	Agomani Sengupta, Preeti Dutta Gupta, Piyali Sengupta, Sharmistha Chatterjee
Direction	Indira Mitra

ভুশক্তির মাঠে

যদি প্লিরিচুয়ালিজম বা প্রেততত্ত্বের খবর রাখেন না তাদের ব্যাপারটা সংক্ষেপে বুঝিয়ে দিচ্ছি। মানুষ মরলে ভুত হয় এটা নিশ্চই সকলেই শুনেছেন। কিন্তু এই ছিওরির সঙ্গে স্বর্গ, নরক খাপ খায় কেমন করে? সেটা হলো এই - মস্তিকদের আত্মা নেই, তারা মরলে অক্সিজেন, হাইড্রোজেন, নাইট্রোজেন গ্যাসে পরিণত হয়। আণ্ডিক রা মরলে প্রথমে ভুত হয়ে যেখানে সেখানে বাস করতে পারে, প্রয়োজন মতো ইহলোকের সাথেও কববার করতে পারে, এটা একটা মস্ত সুবিধা। কিন্তু এই অবস্থা বেশিদিন স্থায়ী হয় না। কেউ কেউ দু'চরদিন পরেই পূর্জন্ম লাভ করে, কেউ কেউ দশ বিশ বছর পর, আবার কেউ বা দু'তিন দশক পর।

এই রকম কিছু ভুতদের নিয়েই আমাদের শতদিনটক রাজশেখর বসু ওরফে পরশুরামের লেখা ভুশক্তির মাঠে।

অভিনয়ে

শিবু ভট্টাচার্য	জয়েশ সরকার
কারিয়া পিরেত	পল্লব রায়
নন্দু মল্লিক	অর্নব ভট্টাচার্য
সুব্রধর	নীলাদি ভট্টাচার্য
নেতাকলি	শম্পা সান্যাল
আবহসসীত	হিমাদ্রি নায়ক
আলো	রাজীব দত্ত মজুমদার
পোষ্টার ও মঞ্চের পর্দায় কোলাজ	সত্যজিৎ গঙ্গুলি
মঞ্চ	চিন্ময় রায়
প্রোজেক্টর সহযোগিতা	সৌমেন্দু
পরিবেশনায়	পূর্বপল্লী দুর্গাবত্ৰি সমিতি
পরিচালনা	শম্পা সান্যাল

হিং টিং ছট

হবুপুর রাজার রাজা হবুচন্দ্র ভোরবেলা দেখা এক অদ্ভুত স্বপ্নের অর্থ জানতে চান। রাজার সভাকবি ও দেশের মন্ত পন্ডিতরাও তা বলতে সক্ষম হয় না। এই দেখে সেনাপতি ভিনদেশের বিখ্যাত পন্ডিতদের আমন্ত্রণ জানায়। কিন্তু তাতেও কেনে ফল না হলে রাজা ঘোষণা করেন, যে এই স্বপ্নের অর্থ বলতে পারবে তাকে প্রচুর পুরস্কার দেওয়া হবে। দেশ বিদেশের বিখ্যাত পন্ডিতরা যা পারল না, গ্রামের এক সাধারণ বালক কি করে তা অতি সহজেই সমাধান করল তা জানতে হলে দেখতে হবে আমাদের নটক হিং টিং ছট।

CAST AND SUPPORT

Raja	Rupkatha Datta
Mantri	Ridhima Sengupta
Senapati	Ayushman Dhar
Kotal	Mohit Bhowal
Shabha Pandit	Akshita Ghoshal
Mlecha Pandit	Abhirup Sen
Farashi Pandit	Reyanshi Sen
Chandrabadan	Auronno Ghosh
Ghoshak	Aarohi Kundu
Prahari	Pritish Pal
Gram Bashi	Riaan Roy, Sanvi Bhattacharya, Arini Bhattacharya, Aankhi Bhattacharya
Shutrodhar	Daksha Bhattacharya
Sot Ma	Rushita Sarkar
Music Preparation	Shrestha Sengupta, Sampa Sanyal
Music Play Back	Gunjan Banerjee
Composer Vocal Song	Barnini Sen
Light	Rajib Dutta Majumder
Stage	Rajesh Sinha, Chinmoy Roy
Prompter	Sutapa Bhattacharya, Rupa Bhowal
Narrator	Shreshtha Sengupta
Astt Coordinators	Apala, Sutapa
Costume	Sampa Sanyal
Play	Based on Rabindranath Tagore
Program Coordinator	Abhijit Ghosh
Back Stage Supports	All parents
Direction	Sampa Sanyal

'Rabon-er Dwidha'

রাবনের দ্বিধা

(Ravana's Dilemma)

Youtube Link : <https://www.youtube.com/watch?v=YCAueFwGZNY>

Date: 1st October ' 2022

Place: Sector 15, Part 2, Community Center
Purbapalli Durgabari Samiti, Durga Puja Celebration.

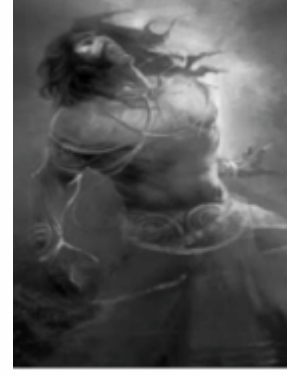

The setting is after the Demon King, Ravana kidnaps Sita and confines her in the Ashok Vatika, in the kingdom of Lanka. Most of his courtiers and ministers support him and hail him for his actions. However, there are a few in his kingdom who try to make him see the right path. They are namely, Vibhishana (brother), Mandodari (his queen), Trijata (the Rakshashi guarding Sita) and Meghnad (his son).

The Valmiki Ramayana and the Tulsidas Ramayana, both have mentioned the internal battle ('Antardwanda') Ravana has to fight with his conscience, given the fact that he was himself a learned and a devout person and had the ability to differentiate the Wrong from the Right.

It is this dilemma of his, that has been highlighted and presented in a musical-dance form, taking some creative liberties and expressed through the various celebrated dance-forms of India and also the western Ballet.

The characters (and the dance-forms) played by our members are as follows:

Rama - **Sanhita Biswas** (Kuchipudi)

Sita - **Chayani Bandhopadhyay** (Odissi)

Ravana - **Sinchita De** (Bharatanatyam)

Mandodari - **Ranjini Basu** (Manipuri)

Vibhishana - **Saumyi Dhara** (Sattriya)

Trijata - **Tashi Dosajh** (Kathakali)

Meghnad - **Rushita Sarkar** (Sattriya)

Sutradhar 1 - **Noyonika Bhattacharayya** (Ballet)

Sutradhar 2 - **Indrani Goswami** (Kathak)

Music Credits:

1. **Bikram Ghosh**

2. **Pt. Rakesh Chaurasia**

Kathak Dance Credits:

Vidushi Saswati Sen

Concept & Choreography:

Indrani Goswami



NODI TUMI KON KOTHA KOU

FOR MEN MAY COME AND MEN MAY GO
BUT I GO ON FOREVER

Rivers are the veins of the planet, essential to human life, the livelihood of human civilization since ancient times. They provide us nutrients through aquatic ecosystems, keeping thousands of species alive and help sustain the earthlings. Over the course of Human History, it has been manipulated for irrigation, urbanization and energy. Rivers are also often the end point for industrial and urban pollution, chemical fertilizer and animal waste. We are dependent on rivers for our survival. But alas, we are unable to maintain the purity of the river due to our unethical practices. It's need of the hour to save the elixir of life. Let's take a pledge to reduce pollution and save purity of our waterways and spread awareness. It's our humble effort to pay tribute to all our rivers.

CASTING

IN DANCING
Souditi Das
Preeti Duttagupta
Mili Majumder
Aditi Ganguly
Suchandrima Mondal
Riya Chatterjee
Puja Modi
Pia Ghosh Roy
Amrita Banerjee
Ruma Biswas
Mausmi Ghosh
Purabi Ghoshal
Akshita Ghoshal
Riddhima Sengupta
Amaneeta Ganguly
Subhanjali Chakraborty
Saumy Dhara
Rushita Sarkar
Aarohi Kundu
Sanvi Bhattacharya
Aarini Bhattacharya
Aankhi Bhattacharya

IN SOLO ENACTMENT
Manashi Chatterjee
Shreshtha Sengupta
Sanhita Biswas
IN SINGING:
Moumita Kundu
Sutapa Roy
Soma De
Soumen Saha
Bhaskar De
Rahul Ghoshal
Prashant Goswami
Sudip Chakraborty

IN RECITATION:
Prisila Chattaraj
Ipshita Chakraborty
Piyali Sengupta
Shoubhik Sen
Arup Kumar Das
COSTUME:
Souditi Das
Manashi Chatterjee
Mili Majumder

Tabla /Dholak	Dheeman Chatterjee
Keyboard	Anirudh Chowdhury
Octopad	Abhirup Chowdhury
Voice Over in English	Arnab Das
Light Management	Jayita Sen
Background Video Graphics	Arnab Das, Arup Chattaraj
Backstage Management	Chinmoy Roy, Tapas Majumder
Special	Rita Ghoshal Mashima,
Thank To	Indrani Goswami, Arijit Das, Satyajit Ganguly, Atrijit Das
Concept	Prisila Chattaraj, Manashi Chatterjee
Choreography	Souditi Das, Preeti Duttagupta, Sanhita Biswas

Music Direction	Co-ordination and Overall Direction
Moumita Kundu	Souditi Das

NAMOH DEBI DURGE

Every year Her presence is felt on Earth... She prevails to bring the good and destroy the evil in our soul. It's time to purify our souls and enlighten in true spirit. It's time for Home Coming. Pooja means a lot to us especially in heart of Bengalis as her own Uma arrives in this world to enrich the lives of her children. The clear blue sky, the hint of shiuli and kash flower's smell in the atmosphere and the hustle everywhere is our beloved Maa Durga's arrival message.

Agomoni or the Song of arrival is a ceremony dedicated to Maa with the spirit of welcoming her. These songs are timeless and upon hearing those nostalgia strikes, memories become more vivid, and the soulful music put us in the groove to kick start the Durga-pooja celebration. These songs are ageless, because with every passing year, a new young Bengalis get to witness the soul of Durga-pooja, and it is etched in the young hearts forever.

Like every year, the people of Purbapalli have set the tone of their arrival to welcome their mother. This year we are presenting a nice garland of songs called "Namoh Debi Durge" to welcome "Maa" at our pandal.

PARTICIPANT LIST

Singers:

Chhandita Warkare
Barnini Sen
Ruma Biswas
Soma De
Sangeeta Bhartiya
Sagarika Patra
Mausmi Ghosh
Sutapa Bhattacharyya
Dr. Soma Bhattacharya
Aparna Chatterjee
Taina Ghosh
Soumi Sarkar
Soumen Saha
Bhaskar De
Prashant Goswami
Kinkar Mukherjee
Sudip Chakraborty
Rahul Ghosal

Tabla:

Dheeman Chatterjee
Shailesh Bhartiya

Instrument:

Monidipa Mukherjee

Narrator

Shoubhik Sen
Urmi Karmakar

Programme Convenor:

Barnini Sen

Behind the Scenes Support

Manashi Chatterjee

ANANDAMELA

Purbapalli Durgabari Durgotsav 2022 had a grand inauguration on 30th September with Anandamela being declared open by our respected President Shri Arabinda Roy, Treasurer Shri Rajat Sengupta and Shri Arup Basu



So finally, this year we managed to break the Covid shackles and celebrate our beloved Anandamela with the usual fanfare. It was great to see the excitement in everybody's eyes as the mouth-watering spread offered by our member chefs were finally right in front of them. Of course, we did retain a few elements from last year's event - like a pre -booking of items (apart from regular on the spot offerings), which helped our chefs with a reasonable idea of the minimum amount of food items they should be preparing. The participation was overwhelming with 32 chefs offering 42 varied items. It was also heartening to see the active participation of quite a few new members.

Our Chefs

<i>Rita Ghoshal</i>	<i>Sutapa Roy</i>	<i>Neeru Chaudhuri</i>	<i>Sutapa Bhattacharyya</i>
<i>Jayati Roy</i>	<i>Soumi Sarkar</i>	<i>Barnini Sen</i>	<i>Apala Bhattacharyya</i>
<i>Urmi Karmakar</i>	<i>Jayita Bhaduri</i>	<i>Mili Majumder</i>	<i>Sarbani Saha</i>
<i>Soma De</i>	<i>Dr Soma Bhattacharya</i>	<i>Shampa Bhattacharya</i>	<i>Jayita Sen</i>
<i>Mausmi Ghosh</i>	<i>Malabika Roy</i>	<i>Jaya Banerjee</i>	<i>Supriya Ghosh</i>
<i>Taina Ghosh</i>	<i>Arpita Roy</i>	<i>Sampa Sanyal</i>	
<i>Rupai Chatterjee</i>	<i>Indira Mitra</i>	<i>Manashi Chatterjee</i>	
<i>Souditi Das</i>	<i>Sonia Mitra</i>	<i>Indrani Goswami</i>	
<i>Suchondrima Mondol</i>	<i>Chhandita Warkare</i>	<i>Agomani Sengupta</i>	

A few firsts this year as we managed to provide all participants with personalized badges and had the option of UPI payment for every stall. All in all, a great event to be cherished until next year.

From the Desk of Anandamela Committee

GARBA

India the land of diversities, makes its dances transcend beyond the fences of socio- cultural hinderances. Garba, Dandia and Navratri go hand in hand to express the vibrance of the festive season, as it celebrates fertility, honors womanhood and pays respect to an array of mother Goddesses. Garba is performed around an earthen pot with a lamp inside. Pot being the symbol of the body within which the divinity resides. The real essence lies in the warmth and togetherness we feel, when we celebrate to express gratitude for being alive. Navratri is incomplete without the resplendent dance form. Our choreography deals with the celebration of womanhood and the divinity in all their manifestation through a fusion of dance forms. We invite all the nimble toes to join in our celebration, come dance with us even if you are an amateur to glorify the mother Goddess and womanhood.



List of Participants

Neelanjana Deb Burman	Pinkee Deb
Manashi Chatterjee	Aparna Chatterjee
Indira Mitra	Ruma Biswas
Sonia Mitra	Mousumi Ghosh
Monalisa Palit	Neeru Chowdhury
Nilakshi Saha Sinha	Krishna Chatterjee
Ankita Chatterjee	Soma De
Urmi Karmakar	Jaya Banerjee
Sarbani Saha	Puja Modi
Taina Ghosh	Soumi Sarkar
Jaitee Ray	Mili Majumder
Suchandrima Mondal	Sutapa Roy
Riya Chatterjee	Barnini Sen
Amrita Banerjee	Souditi Das
Mithu Chakraborty	

*With Best Compliment
from*



**Shopno Motors
Jessore, Bangladesh**

With Best Compliments From

UNISON

UNPARALLELED INSURANCE SOLUTIONS

✉ info@unisoninsurance.net ☎ +91 124 4109440

www.unisoninsurance.net

UNISON Insurance Broking Services Pvt. Ltd.

705, 706, 707, 708, 709, 710 & 711

7th JMD Regent Square Tower, M.G. Road, Gurugram - 122002. Haryana, India

Vadodara - Head Office | Mumbai - Corporate Office

Ahmedabad | Ankleshwar | Bengaluru | Chennai | Gift City | Gurugram | Hyderabad | Noida | Surat

With Best Compliments From



SHREE AMBA AUTO
Kathmandu, Nepal

With Best Compliment From



Upender Sharma

With Best Compliment From



Sandeep Anand

With Best Compliment From

Mukesh Aggarwal



Satyam Enterprises

Mishri Bhawan, Mehtab Singh Ka Nohra,
Alwar-301001 (Raj.) M.: 099280 28009
Email: satyament@hotmail.com

With Best Compliment From



Rana Chowdhury

With Best Compliment From



Niranjan Saha

With Best Compliment From

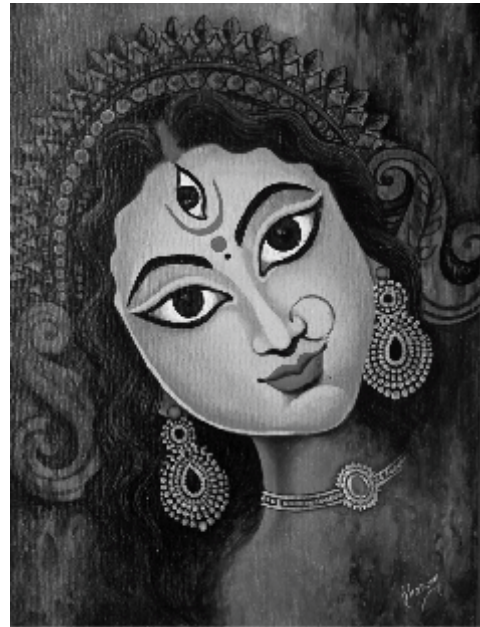

Sunrise Carriers
(Suman Pal/Jagannath Pal)

With Best Compliment From



Bijoy Kr Sharma

With Best Compliment From

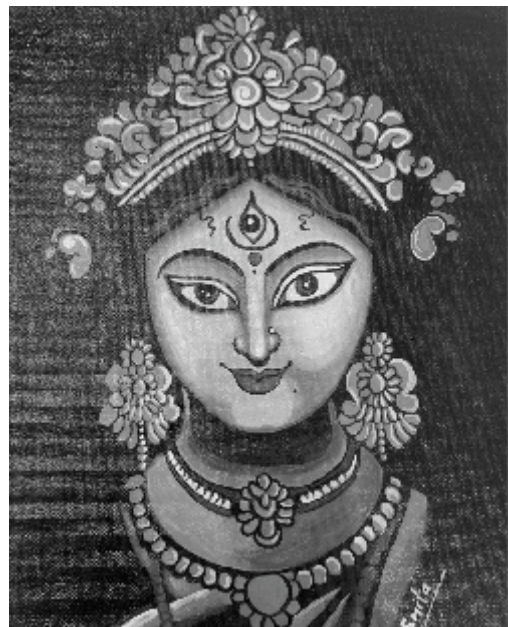

Bhagwan Prasad Saha

With Best Compliment From



JAMAN AUTO, JESSORE

10, Mohsin Super Market, R.N. Road, Jessore, Bangladesh



Model : ER CAR AMPLIFIER KIT
 Car Amplifier Wiring Kit (HIGH QUALITY)

hifi
ER
ANTENNAS

PARTS INCLUDED

- 100% 100% COPPER WIRE WITH
- GROUND STRIP CABLE SOCKET
- 2000CM SPINLOCK FOR THE CABLE SOCKET
- "3000CM ENCLOSED"
- CLEAN AND STRENGTH ANTENNA
- SHIELDING SHIELD
- 100% 100% COPPER WIRE WITH
- 100% 100% COPPER WIRE WITH
- 100% 100% COPPER WIRE WITH
- 100% 100% COPPER WIRE WITH
- 100% 100% COPPER WIRE WITH
- 100% 100% COPPER WIRE WITH

8 GAUGE Amplifier **INSTALLATION KIT**
 Suitable for any 2 Channel Amplifier

POWER TO THE BATTERY
 SHIELDING CABLE Braid
 8 GAUGE 20 FT. THICK & 1/4" DIA. RIGID
 THERMOPLASTIC SHEATH
 CLEAN AND STRENGTH ANTENNA
 SHIELDING SHIELD

GROUNDING STRIP
 100% 100% COPPER WIRE WITH
 100% 100% COPPER WIRE WITH
 100% 100% COPPER WIRE WITH
 100% 100% COPPER WIRE WITH
 100% 100% COPPER WIRE WITH



With Best Compliments From

INSSAN-NIC

MANAGING COUNCIL

Chairman - Mr. Yogesh Munjal
General Seceretary - V.K. Srivastava
Jt. Secretary & Finance Secretary - Satya Prakash
Ex. Member - Naresh Gandhi
Ex. Member - Jagdish Prasad

With Best Compliments From



TRANSWORLD

C-109, Sector-A. Mahanagar Nagar
Lucknow - 226 006, India/
Tele / Fax : +91-522-4009886
E-mail : info@transworld.in

With Best Compliment From

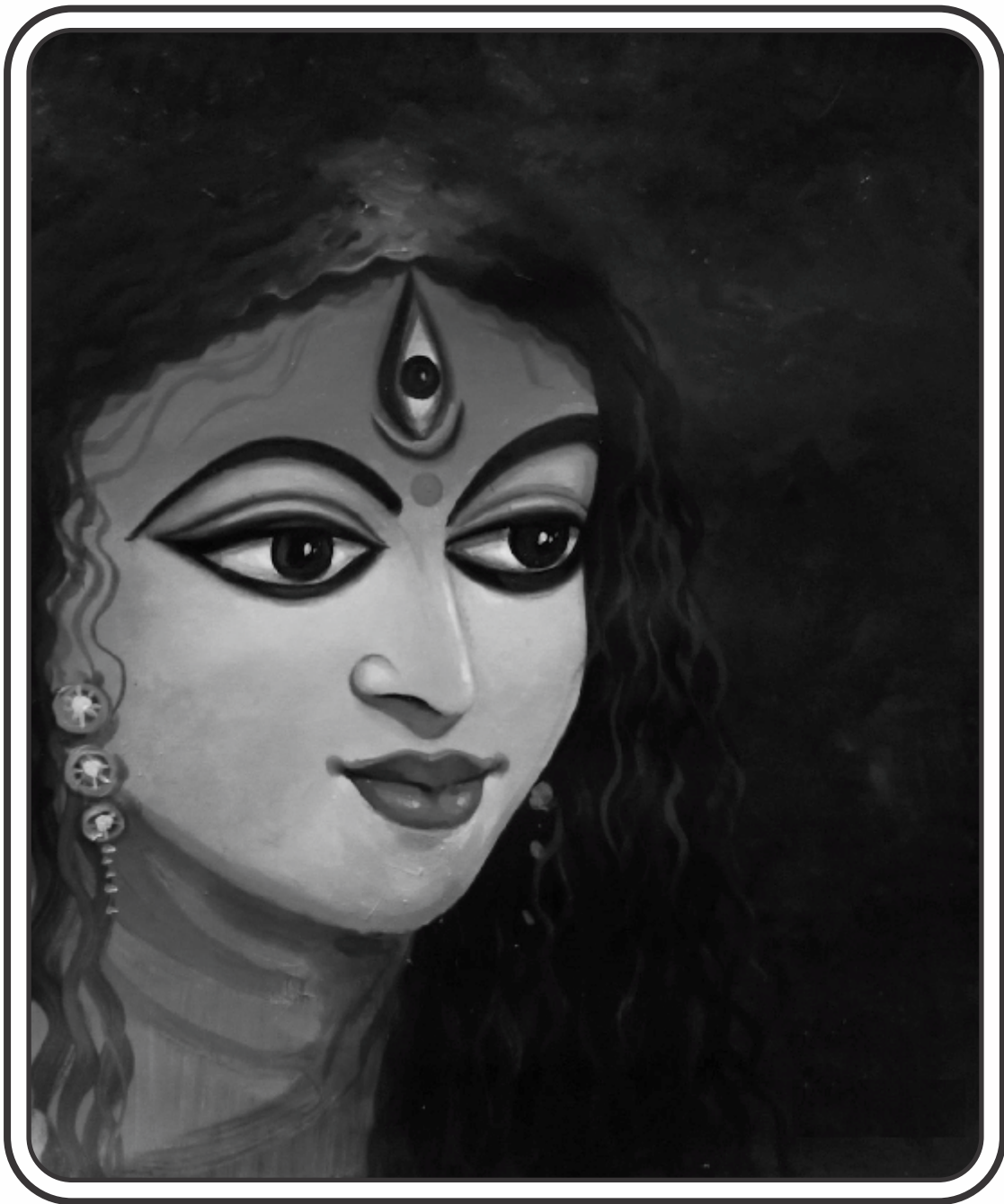

Amar Transport Pvt. Ltd.
Bagalkot

With Best Compliment From



Amit Kr Saha

With Best Compliment From



Dr Sharat Latta

With Best Compliment From



Ajay Prasad

With Best Compliment From



**Sri Srinivasa Agencies,
Davangere**

With Best Compliment From



SK group is potential OEM Autoparts supplier Pan India. They have 6 plants all across India ,also exporting to 22 countries through OEMs.

We are no 1 door deflector films supplier in India ,also supplying Injection Moulding , PU moulding, various foam parts.

Our main products door sealings , foams, thinsulate, thermo formed ,parts, stickers/labels, fendor foams, expandable PP where we have japanese collaboration. Also we make Thinsulate with Korean approvals lksung.

We wish Purbapalli Durgabari a very happy Durga Puja 2022. May Goddess shower peace , tranquility and prosperity.

(Our Major customers, Swaraz Mazda, Isuzu, Maruti, Mahindra, Kia, Hyundai, MG, motors. VW.)

Our punch line “Yes, We can do it”

TEAM SK GROUP.

contact@sellowrap.com

Sellowrap Industries Pvt. Ltd.

Plot No GP-54 Sector 18 ,Maruti Industrial Estate

Gurugram, Haryana 122 015 | India

Tel : +91-124 4015 973 |

Mob : +91 - 9999786142, +91 7982518124

IFFDC

Preserving Nature . Nurturing Lives

Indian Farm Forestry Development Co-operative Ltd. (IFFDC) promoted by Indian Farmers Fertiliser Cooperative Ltd. (IFFCO) was registered on 22nd October, 1993 under the Multi-State Co-operative Societies Act, 1984.

IFFDC is working in the five core areas - Green Cushion Development, Ecological Resilience and Climate Change, Nutritional Security for Rural Poor, Agricultural Inputs and Corporate Social Responsibility with the Special emphasis on five components viz; Jal (water), Jangal (forest), Jameen (land), Janwar (livestock) and Jan (human).

IFFDC has become a unique model for large scale adoption in the field of afforestation on wasteland and integrated rural development for socio-economic upliftment of the farmers. IFFDC is presently working in 18 states of India. It has covered 29,421 ha. wasteland for afforestation and total existing trees are 109 lakh by promoting 172 village level Primary Farm Forestry Cooperative Societies (PFFCS) with a membership base of 21,119. (38% women members)

For Climate Change Resilience Development, IFFDC is implementing Watershed Development Programme. 17,740 hectares land treated with soil-water conservation measures, constructed 272 Check Dams, 1159 ponds, 1293 wells and 326 LDPE Tanks. It resulted into increased 15,171 hectares area under irrigation, helped in bringing crop diversification, reduction in erosion upto 0.86 lakh ton every year, the crop yield of these farmers increased upto 1.5 times and generated 1.04 lakh mandays employment

IFFDC is the main implementing agency for "IFFCO-TOKIO Integrated Rural Development Project" of IFFCO Tokio General Insurance's CSR Initiative in Rajasthan and Odisha. The Project is being implement under these segments viz; 1. Community Health and Sanitation, 2. Safe Drinking Water, 3. Water Resource Development, 4. Agriculture Development, 5. Women Empowerment, 6. Skill Development and Employment Creation, 7. Animal Husbandry Development, 8. Environment Up-gradation, 9. Education

IFFDC has undertaken Seed Production and Marketing in the states of Uttar Pradesh, Haryana, Punjab, Rajasthan, Madhya Pradesh, Himachal Pradesh, Bihar and West Bengal to increase availability of quality seed and thus enhance agricultural productivity.

IFFDC has been selected for The Times of India "Social Impact Award" under the Livelihood category in 2011 and also in the year 2015, Environment Sector under Corporate Category for its outstanding performance in environment protection and development. IFFDC has also bagged the Prestigious national award "Indira Priyadarshni Vrikshamitra Award".



INDIAN FARM FORESTRY DEVELOPMENT COOPERATIVE LIMITED

(An initiative of IFFCO)

FMDI, IFFCO Colony, Sector-17B, Gurgaon-122001

Phone No. 0124-2340148 Fax : 0124-2340149

E-mail : iffdcheadoffice@gmail.com; Website : www.iffdc.in

"Challenging Poverty Through Enhancing Rural Livelihood"

LAPL AUTO PARTS

The light that gives safety to whole world,



LAPL Automotive Private Limited
C-241, MIDC Waluj, Aurangabad, Maharashtra 431136
Contact :- 9225364621
Email :- Customercare@laplautomotive.com



*With Best Compliment
from*



Value Homes
(Sushil Kumar Sharma)

With Best Compliment From



**Anil Kotnala
& Family**

With Best Compliment From



Rana Chowdhury

With Best Compliment From



Priya Rubber

Deochara, Dharamnagar,
North Tripura

With Best Compliment From



Wellwisher

*With Best
Compliments From*



DR. SATYAN

With Best Compliments from



UTTAM SUCROTEC

With Best Compliments from



HONNIKERI SIDDESHWAR TRANSPORT COMPANY

Shop No. 149, 1st Floor, Near Gandhi Circle,
Gandhi Gunj, Bidar - 585401, Cell : 9591187815



VARAT PUMP & MACHINERY PVT. LTD.



**Non Clog
Sewage Pump**

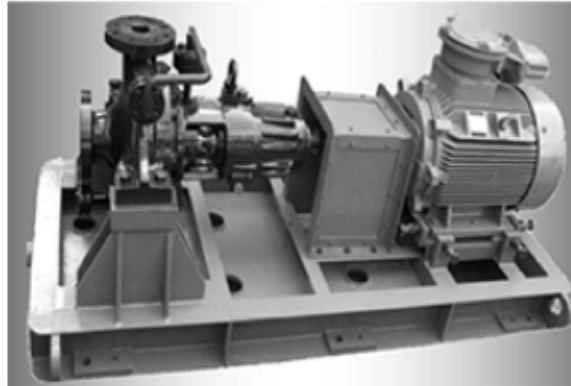

API Pump



**Submersible
Pump**

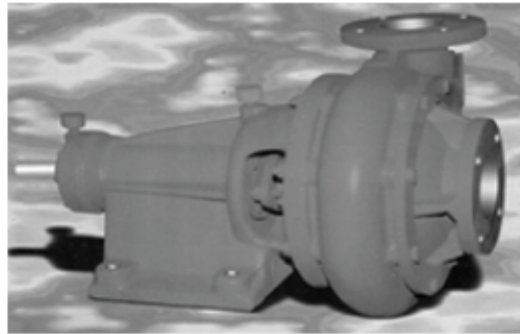

Non Clog Pump

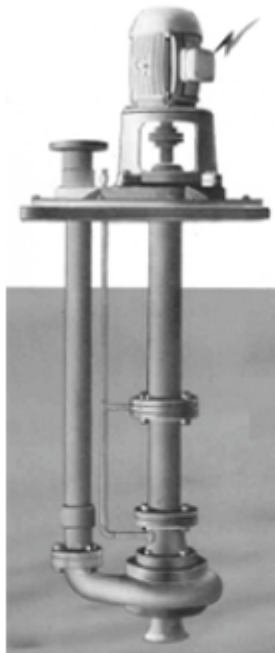

Sump Pump



Fire Fighting Pump



**Vertical
Turbine Pump**

With Best Compliments From



RAVI SHARMA

Proprietor, Neweratools@yahoo.com

New Era Tools

AUTH DEALER: TUNGALOY

Deals In: All Kind Carbide Cutting Tools Used in CNC & VMC Machining

SECTOR 40 LUDHIANA

A Journey to Hope

Tapas Mitra

A small city built as replica in Washington DC in Canada for First Blood-Sly Stone. 1982, on 40 th Anniversary of Rambo-1st blood

My son, Sayan, migrated to Canada at tender age. His strong hobby was travelling and snow. After completion his course, he joined job, and started fulfilling his travel urge and dreams.



He was explaining once me, he travelled near the shoot spot of First Blood- Rambo-1 in British Columbia.

The director-producers built a small township with a bridge, petrol pump, drug store, police station. It was in very interior of BC, but some how he reached the stream, cliff from where he jumped etc.

It was something like Sholey village created off B'lore by Sippy.

The bridge in HOPE is no more now, the lake ,small province of DC Washington – Hope-city is still there as tourist attraction and a sculpture of Sylvester Stallone installed. Sly was stationed there for 3 months.

Its exciting journey and memorable to him. Next time another exciting event cum journey with pics will be placed for you.

Hope is still there , a wooden sculpture is created on his memory and placed.

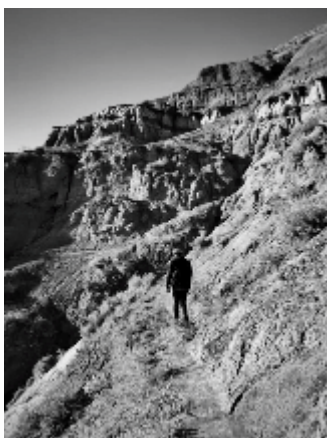

আমি ও স্বপ্ন

- Indira Mitra

আমার ব্যক্তিক্রমী স্বপ্ন, খুঁড়ি আমার স্বপ্ন না ---আমি ও স্বপ্ন।

দুজনেই আমরা একেবারে হরিহর অঙ্কা। অবাধ পরিধি আমার তার কাছে আর স্বপ্ন র ও খুব সাবলীল বিচরণ আমার কাছে।

সকাল থেকে উঠে সাংসারিক দায় দায়িত্ব সামলাই আর পাঁচটা গৃহিনী র হাত, সাথে স্বপ্ন থাকে চিন্তনে মননে, সে যে আমার এ কমাত্র পরম যাকে আমি উজাড় করে দিই, কোনো ঘেরাটোপ নেই, নিঃশর্ত চওয়া পাওয়া। সে ও আমার দেয় অফুরান ইচ্ছা শক্তি, প্রেরণা মনোবল, জটিল সমস্যা সমাধানের সরল নিকাশি।

যা আমি সায়াদিল খুঁজি স্বপ্ন ঠিক খুঁজে দেয়।ও না আমার জন্য খুব পরিশ্রম করে বদলে কখনো বলে না "তোমার জন্য এই করেছি --

ভাই করেছি "।রোজ আমার কত জামগায় ঘোরায়, পুরাতন কে নতুলের সাথে মিশিয়ে দেয়, আমার না কথা বলে ওঠা কে কি সুন্দর ভাবে বলিয়ে দেয়, না পাওয়া কে পাইয়ে দেয়, আমার শৈশব, কৈশোর, যৌবন কে নতুন রঙে রাঙায়, সাহাড়া মেঘ সমুদ্র কে একাকার করে দেয় আমার অজানা র খোঁজার গাথে। আমার অত্যন্ত আশ্রয় মারা চলে গেছেন জীবনের মায়া ত্যাগ করে--

অসীম ক্ষমতায় স্বপ্ন তাদের সেই অসত্য, স্নেহ সমতায় তাদের শাসনে আবার ভরিয়ে দেয়। হয়ত বিরূপ আমি কোনো সম্পর্কে, --কি উপরিসীম শক্তি-- পুনরায় নিটোল সম্পর্ক গড়ে তোলায়।

এথরও আমি আমার সেই ছোট দুটি সন্তানের নরক উষ্ণ ছোঁয়া, দুধ দুধ গন্ধ, কতো গল্প র মিষ্টি আবেশ অনুভব পাই।

ফুলশস্যর সেই লম্বা রাঙা মুখটি পুকাই অবগে কাছে টেলে নেওয়া আমার পুরনু টির বুকো।

ভাই ভে' রাত্ত আমার পরম প্রিয় স্বপ্ন। স্বপ্ন ভূমি ঠিক আসবে আমি জানি কত রুপে কত বেশে কত দেহে মনে দেশে--'

সংসার সংগ্রামের শক্তি বেগাথে---আরো আরো ভালোবাসা দিতে, শেখাতে ---সে ও যেন অপেক্ষা করে আমার জন্য।

আমার সংসার কে আমার বিশেষ শ্রদ্ধা ভালবাসা---তার জন্য ইতো স্বপ্ন কে পাই।

FLAMINGOS

Auronno Ghosh, class V

Flamingos are beautiful. They eat algae and shrimps which contains carotenoid pigment which contributes to their fabulous pinkness. Mom and dad flamingo are team players. Together they build the nest and incubate eggs. It takes long years for these birds to get this pinkness. During winter flamingos migrate to Mumbai and its awesome to watch them. I love flamingoes for their grace and flight.

I have tried to capture in crayon these beautiful birds here....

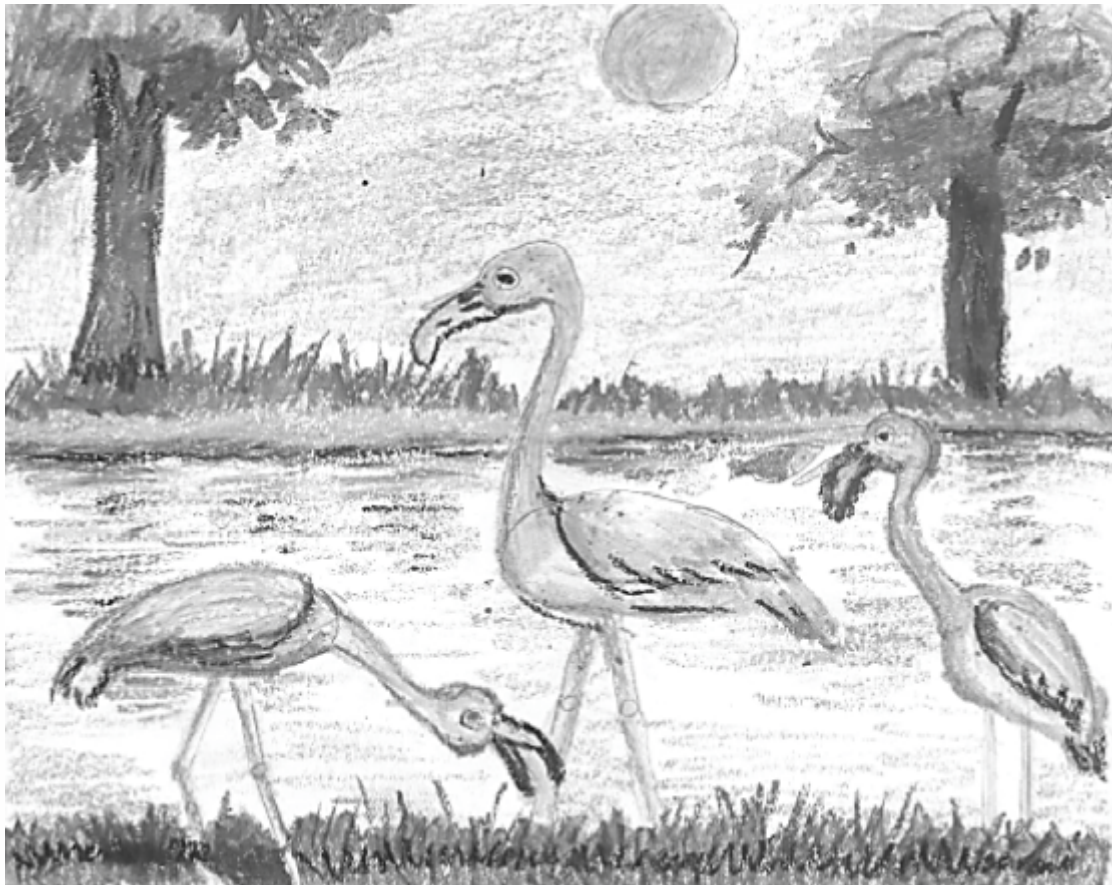

পিতৃ-ঋণ

আজও আমার মনে পড়ে
তোমার হাতের কাগজ খানা
তোমার কলম তোমার লেখা।
ব্যস্ত সকাল শান্ত দুপুর
তোমার বলা শেষ কবিতা
আমার তোমার ভালোবাসা।

বলতে তুমি, "ছন্দে লিখবি কবিতাখানা ছ'মাত্রা, আটমাত্রা-
কখনো ধরবি, কখনো ছাড়বি।
বাঁধন তাতে দৃঢ় হবে,
শব্দ লিখবি সহজ সহজ
পড়তে সহজ, লিখতে সহজ
লোকে পড়বে,
শুভ হেউক তোর যাত্রা।"

আজও আমার মনে পড়ে
রবিবারের শব্দ-জব্দ
তোমার সঙ্গে কাটাকুটি
বানান ভুল আর খুনসুটি।
মাঝে মাঝে ছন্দ গুলো
মনের মধ্যে দানা বাঁধতো।
তালে তালে ছন্দে ছন্দে

রান্নাঘরের ঘটি-বাটি
আমার হাতে,
তুমি লিখতে কবিতাখানা-
হাতে কলম, চোখে চশমা।
বলতে এসে, "দেখতো পড়ে
কবিতাটা, ভালো লাগছে?"
কী বুঝলি একটু বলনা।"
বলতাম আমি, "বাবা, আমায় লিখতে শেখাও,
গড়তে শেখাও ছন্দখানা।"

আজও আমার মনে পড়ে
তোমায় দেওয়া শেষ কথা-
লিখবো আমি এক পৃথিবী
লিখবো আমি তোমার সাথে
তোমার কথা মনে রেখে,
পড়বো আমি, পড়বে সবাই
আমি তখন বলবো হেসে
বাঁচিয়ে রাখবো তোমার কবিতা
তোমার বলা, তোমার কথা
পিতৃঋণ যে শোধ হয়না!

-ঈঙ্গিতা

দুর্গা যাবেন বাজারবাড়ি*

দুর্গা যাবেন বাজার বাড়ি, সজ্জা সাজকে।
লাফি-সুরা গুলু-কোড়া, কোমর বেধেছে।
সায়র-বানান, ইস ও ইয়র, প্রবণ সালে যাবে
কাচ-দুর্গা পিন, তাক-ঘানা-ধিন সজ্জা করেই খাবে।

যাবেন গুণ্ডা জাল্লাজি রোজ একই ক্রিনিস য়েতে?
এ গুণ্ডা জাই চাই কাটা দিন অন্য কিছু নেতে
হলেও ভস ও-দ্রোমবস, বাকনু বসি ডরা
চক-রোল-সুই, চুট-গোজলাই, বাদকী পটাল করা।
চিকেন-সুচেন-বিলিয়ানি হাচ স্মিনি হাচ লাভলি।
কোজা-করাব কোসা-লোলাও, সুচকা-সালুকবালি।
বোদে-রাজা স্ত্রিগিয়া এবে সবজাজা, মরনুবিয়া
বাসগেল্লা পাঞ্জমবাত্ত অর্ডেই ইক্ষয় কুইয়া ॥

নাখাম খাবো অ্যামস কবেই, স্মিফিনা-চসচস।
দই-গন্যার-দববেলাও বেস, খায়ে/বারি কেসকস।
দুর্গাশেরী বহলে: লেটুক ধলাব তোমের মল্ল
চারি এবাবে অ্যামার সাথে বাওয়া তোদের বকা।
শুনেই জোরে কাঁদতে থাকে গল্প-পাঁচ-ইস
সোথেব ডালে, নাকের গুল মব কবে খামহাম!
সে বলেলেনু, খাবি-খাবি খাজা কালারসুর-বে
টেঁচায় সযাই, খাম্ব ইটু গ্রহ হিনাইল হিল কুবেথো।

সম্প্রদায় লীগ

The Queen, PM and I!

Nilakshi Saha Sinha

Queen Elizabeth-II (referred hereinafter as the Queen) passed away recently on 08 September 2022 at the age of 96. She was a towering figure of the 20th and 21st centuries and dominated British history and politics over the past more than seven decades. She was a world figure respected and admired by one and all for her utter sense of duty and devotion to her role as Britain's monarch.

It would not be out of place to mention here that I lived in London as a child from March 1975 to August 1978 – the very crucial and formative years of my life. When the Queen celebrated her Silver Jubilee in 1977, I was a nine-year old kid in a primary school in South West London. The Jubilee was celebrated in a big way throughout the year. Every child in our school was given a commemorative silver coin which till today, I have kept very carefully and will always cherish it.

All this is the backdrop to understand how excited I was when I came to know that the Queen would be hosting a lunch for our Prime Minister, Shri Narendra Modi, during his visit to the UK in November 2015. As you all know, I served as the PM's Interpreter from 2014 till earlier this year. I used to cover all his meetings with world leaders and top CEOs essentially interpreting from Hindi to English (and French when required).

I still remember so vividly that morning of 13 November 2015. It was an early morning for all of us (the delegation members of Hon'ble PM) as we were at Chequers – the official country residence of the British PM. Chequers is a large English-style 16th century manor house some 64 km north-west of London. We had arrived from London the previous evening directly after landing. There were talks between the two PMs (PM Modi and PM David Cameron) over dinner which ended very late. For me, the day had started very early in India and ended very late in the UK (which is 5 and ½ hours behind India)! I had barely slept five hours but I was up early on the 13th and chose to wear my pista green Baluchari – a personal favourite. I had specially bought a mauve coloured jacket from Fabindia to match with its embroidery. I dressed with care since I knew that I would be going to Buckingham Palace to meet the Queen. But before that, there was work to be done – there was a meeting once again between the two PMs just after breakfast at 8 am! I still remember the mahogany walls of the Chequers library where the restricted meeting took place. As soon as that meeting got over, the PM and only a select few (including me) of his entourage boarded a Royal Air Force chopper for a short ride to St. James' Court Hotel (a Taj Hotel) in the centre of London where we were staying. I was so excited to board the chopper (in my saree!) and have an aerial view of the English countryside and London. That was my first chopper ride ever. Of course, later, I took so many chopper rides in India, Sri Lanka and Israel while accompanying the PM. It felt so good and exhilarating to see the lush green landscape – I took a few photos from above. After landing, we had about half an hour to freshen up. This was still mid-morning. As I

freshened up, I put on the TV to catch up on the news – I was aghast to see the terrorist attacks in Paris unfolding then. Paris has a special place in my heart – I call it my second home having lived there for more than six years. The Bataclan Theatre Hall was under siege. It was horrendous to see how people were trapped and were being killed by terrorists... I quickly switched off the TV and proceeded to take my place in PM's motorcade – only our High Commissioner, Amb. Ranjan Mathai and I were to accompany the PM to Buckingham Palace.

As my car entered the gates of Buckingham Palace, I had goose bumps – so many hours spent in my childhood standing outside those Palace gates and walking around leisurely in the locality during our family outings – did I ever, in my wildest dreams, imagine that I would drive through those gates and ascend the steps of the Palace? No, never! I was excited like a child!! Our coats were taken at the entrance and then the three of us (PM, HC and I), were escorted to the first floor taking the grand staircase. The Queen's Protocol team briefed us about the sequence of events. The Queen would receive the PM and shake hands with him. There would be a photo opp. After this, she would accompany the PM to the Banquet Hall where I would be pre-stationed. After the luncheon, the two dignitaries would proceed for an exchange of gifts which were displayed in a hall.

As the Queen and the guests sat down for lunch, I was seated in between and slightly behind them. I was so close to the Queen, barely inches away from her face that I could not but help admire how well preserved she was – at 89, she was radiant! More importantly, she was so well informed and absolutely in the present moment. She was mentally and physically all there. I saw her medium heels with admiration thinking whether at her age, if my legs would permit me to wear heels...The luncheon being a private one, no cameras were allowed. I was just lamenting to myself that there would no photos of this historic meeting for posterity...Little was I to know what would happen after lunch!

The conversation over lunch between the dignitaries was a very interesting one. Two points are worth mentioning. First, was the conversation regarding Myanmar. Elections had just taken place there and Aung San Suu Kyi's party had won a majority. She was to set to be appointed as the State Counsellor (de facto Prime Minister). The Queen mentioned that Lord Mountbatten had brought Suu Kyi's father, Aung San, to Britain for talks. After mentioning this, she burst out laughing and remarked, "This just shows how old I am!!!"

The second very interesting point was about the use of technology. We are all aware about how tech savvy our PM is and how he has pushed for the use of technology in all fields for "Ease of Living". I was amazed to see how enthusiastic the Queen was about the use of technology to save on time and money. The Queen asked PM if he was attending the CHOGM (Commonwealth Heads of Government Meeting) in Malta later that month. PM replied that he would not be able to as there were a series of summit meetings taking place during November 2015 which he would have to attend. However, in his place, our External Affairs Minister (late Smt. Sushma Swaraj) would attend. PM mentioned that from the UK, he would be going to Antalya, Turkey for the G20

Summit. After that, he would have to attend the East Asia and ASEAN Summits in Malaysia. He would also be attending the COP 21 (Conference of Parties to the UNFCCC) in Paris later in November. There were some domestic preoccupations too. The Queen replied that it was very difficult when so many summit meetings get bunched up together in this manner! PM said that he would be suggesting that 2-3 summit meetings should be organized at the same venue with half a day dedicated to each one. By doing this, we would be saving on time and money and working more productively. The Queen thought that this was a very good suggestion although she remarked that it might not go down too well with the world leaders! She added that some summit meetings could also be done through video conferencing (how prophetic her words were....). PM agreed and said that one year, it could be done through VC and the following year, the leaders could meet physically. The Queen remarked that technology should be used to the fullest extent. The whole COVID experience demonstrated how the entire world had to adapt to what the Queen and PM had said! When the dessert was served, PM was not too keen to have it. The Queen said, "I never give the pudding a miss!" I really found that very sweet – in primary school, I always looked forward to the "pudding" (dessert) during my "school dinners" (the British word for school lunches).

After lunch, the two dignitaries were escorted to a hall in the Palace where the gifts to be exchanged were on display. As the three of us (the Queen, PM and I) entered the hall, it appeared that the whole world's Press was present there! There were thousands of flash lights and TV crews filming away as the Queen and the PM spoke about their respective gifts. If searched on the Internet and especially on YouTube, you will find many beautiful photos and videos of this particular event. I have preserved all these in my personal collection.

PM explained his gifts - the three framed photos of the Queen's visit to India in January-February 1961 when she was the Chief Guest at the Republic Day parade. During that visit, she had toured Varanasi, Ahmedabad, Jaipur, Udaipur, Kolkata, Mumbai, Bengaluru and Chennai. The first photo showed her visiting the Sabarmati Ashram in Ahmedabad, a day after the commemoration of the 13th death anniversary of Mahatma Gandhi. The second one showed her cutting a cake to celebrate the first birthday of Prince Andrew in Chennai during a civic reception and the third photo was her elephant ride in a procession from Nandesar to Balua Ghat in Varanasi. The Queen was visibly moved on seeing these photos taken 54 years earlier. She was reminiscing about that first visit to India and described how overwhelmed she was while addressing a huge public gathering at Red Fort where there were people "as far as the eye could see"! In addition to these photos, PM gifted some award-winning Darjeeling tea from Makaibari Tea Estate in West Bengal, fine organic honey from Jammu and Kashmir and Tanchoi stoles from Varanasi. The Queen, in turn, showed PM a display of artefacts from the Royal Collection. She proudly showed the lace shawl made from yarn spun by Mahatma Gandhi in prison which was his gift on her wedding to Prince Philip in 1947. There were other items on display too which unfortunately, I cannot recollect now. It was wonderful interpreting for both of them. The Queen was very appreciative of the quality of interpretation and looked very happy as she bade the PM "Goodbye"!

The next meeting between the two dignitaries was on 18 April 2018 when the UK was hosting the 25th CHOGM (Commonwealth Heads of Government Meeting). Although this meeting was special but definitely not as special as the first one in November 2015!

The Queen was meeting many of the HOS/HOG (Head of State/Head of Government) during the CHOGM. PM's meeting was scheduled for the morning of 18 April. This time, only I was to accompany him. I remember I wore a rich magenta coloured Mysore silk saree that day. As we arrived at the Buckingham Palace, we were once again briefed by the Palace Protocol about the sequence of events. It was a nice and cosy meeting this time. The only people present were the Queen, PM and I. The Queen gifted PM a large coffee table book on a special exhibition on India which was to take place at the British Museum. PM's gift, as is the norm, was exchanged through the respective Protocol Departments. The meeting would have lasted about half an hour. There was a certain ease between the dignitaries and the Queen, like the last time, was very much in her elements and extremely well briefed. She was warm and hospitable.

It was quite evident that the Queen's health deteriorated sharply after the passing away of her husband, Prince Philip in April last year. They had been married for 73 years... She survived her husband for less than a year and a half and her demise last month unleashed a host of memories which I have tried to share with you.

A Real Story....

I share this true ghost story which actually happened in my family probably minimum 50 years back.

My father's great grand father was a civil surgeon in a small town of UP. I do not remember exactly in which town he was posted. The britishers' had provided him a huge bungalow with all facilities & he lived with his family, happily spending good time doing service to humanity.

Since he was a doctor by profession & that too in a small town those days, the population there respected him a lot.

He had become popular in near by towns too...

It was monsoon time & that night it was pouring cats & dogs. Being a small town, the roads were not too good though he owned a vintage four wheeler. Time was all good & in his favour.

It was late night & the family after dinner had gone off to sleep. It was anyway pouring outside & the weather had turned cool, so they had used a 'chaddar' to cover themselves & so a sound sleep.

At about after midnight, somebody rang the door bell.

The doctor wandered probably somebody needs his help for some kind of treatment. So he got up to check at the door. He opened & found a man standing in front of him, appeared to be a poor man from a nearby village. He had rapped himself with a cloth which was all wet as it was pouring outside.

He enquired about his problem & got to know that somebody in his family was sick & requested the doctor to go along with him & check upon the family member & give the necessary treatment.

Though he had a driver who was sleeping in the servants' quarter, he didn't want to disturb him. He drove himself & followed the person who was in his bicycle.

Both drove @ a slow speed as the visibility was not clear.

After covering quiet a distance, & almost reaching the home of that small village, he found the man missing.

The doctor wondered what is happening...

Some body whom he followed all the while could disappear ?

The doctor was very confused. He tried to enquire describing the person whose family member was unwell but nobody could actually reply...

Since it was late midnight & it was pouring, & no answers, he came back home with his mind completely blank.

He discussed with his family members & they too were dazed. Next morning he enquired with his staff but nobody knew or give any details.

Being day time, he decided to go back to the same location, this time with the driver reaching the same village. All villagers recognised him & started taking good care of him.

Everything was fine but he pondered about the incident & so he couldn't stop asking & enquiring about the family.

The villagers' were surprised about his visit during late midnight.

When he described the person & the whole incident, he got to know that years back, this villager existed & yes one the family member was really seriously sick. This poor villager ran for a doctor & by the time, he could arrange for a 'Vaid', the family member passed away.

Actually it was not just one family member but the whole family had fallen sick except this villager, & all were on death bed.

Due to non treatment, he lost all his family members. Since he was left out alone in that house, & not able to bear the loss, he committed suicide.

I understand in such cases, the soul can never die out or remain stable & so wanders in the surrounding.

This whole incident is true & was shared by my father when he was alive.

Any of us, on reading may or may not believe it to be true.

I shared as shared with me.

Thanks for patiently reading it.

Regards

Sandip Ghosh Sec 15/II

PP member since '96

Unwind Kaiserbagh

I vividly remember those summer vacations when I would visit Kaiserbagh which is a locality of Lucknow in the vicinity of East Gate opp Baradari... a prominent land mark.

The common wall is that of Nehru Hospital, earlier National Herald.

There lived my fathers' uncle Sri Sheetal Prasad Roy & his wife Smt Shobha Roy & their only child & son Sri Phalguni Roy. My father Sri Sameer Kumar Ghosh was a member of that house & for quite a while my father & Sri Phalguni Roy grew up together while they were both studying in Lucknow. My grandmother was also a part of that house.

Sri Sheetal Prasad Roy was in the Judiciary holding a high position as a criminal lawyer. All cases that reached him would go for order as Hang To Death... quiet a fearless person.

This particular huge area appx 200 acres & was a palacial house with a treasure room which was all sealed. Actually if I mentioned & it was true that it's the burial place of a saint by the name 'Pir Baba' & so was also understood that the basement was all sealed as it has precious stones beneath. In fact the whole of Kaiserbagh had such secret places where treasure was buried & it was understood that whosoever tried to dig for the greed of treasure would not live further.

Now it so happened that when Nawab Wazidalli Shah, the last nawab of Lucknow left the city as the British took over, my great grandfather was a Khajanchi (treasurer) in the kingdom of Nawab & because of his honesty & sincerity gave away the whole of Kaiserbagh as a gift to my great grandfather.

Down the line Sri Jitender Nath Roy who was given the title as Rai Bahadur took over the whole of Kaiserbagh. Being a huge area, most of it was given away to his distant relatives. All of the portion had pre built houses which were occupied by the relatives & bigger portion by the "Roy's". Next after Rai Bahadur who also was in the Judiciary gave away to his son Sri Sheetal Prasad Roy. Next was the turn of Sri Phalguni Roy, son of Sri Sheetal Prasad Roy who later of course left for London to study Taxation & Law. That was way back in '60s'. He worked hard, became a professional, settled with a Dutch lady as his loving wife & they were blessed with a son Mr. Raoul Roy. I understand they were a Happy Family. Mr. Phaguni with family would visit India probably once in 5 years but was not allowed entering his own home... Kaiserbagh as he had married a foreign lady. There was lot of misunderstanding between father & son. They would also visit us in Bombay (Mumbai). My father later after completing his studies had joined the Railways & was posted in Mumbai. Though the 'Roy's' would stay up in a good class hotel when they visited us but would visit us daily for most meals & would also go out visiting places in Mumbai & we accompanying them many a times.

Later on when Senior Roy passed away but till the time his mother lived, he had started putting up @ his home with family.

After his mother too passed away, he started visiting India frequently & stay @ his hometown home Lucknow for a longer period but had to go back every time.

Maintainence of the palacial house would cost atleast 50,000/- every year plus the driver & maid were all paid through out the year even during his absence. Ofcourse during his presence while in Lucknow, he had the habit of visiting relatives & friends

About 5 years back, there was a unfortunate change in his lifestyle. He was approached by a Muslim gentleman through his driver. I will not mention the name of the Muslim gentleman as he is suppose to be a 'DON' as understood so always be away from such category of persons or groups. He came with an offer to take care of the house during the absence of Sri Phalguni Roy when not in India. I guess a deal was done & some money matters was made from both sides. Not too sure ...what was the deal & whether there was any money involved.

A week... 10 days before he had booked tickets to take the flight from delhi with a break journey in Gurugram which was a routine whenever he visited India fell severely ill & had collapsed @ his Lucknow home while he was about to end the day for a night sleep. He layed on the floor the whole night & only when the driver came next morning, Sri Phalguni Roy shouted @ the driver to pick him up. So the downfall had started & the situation unstable. Mr. Phalguni Roy did a break journey in Gurugram & it was usual here not knowing that things were already bad. He collapsed in the plane before he reached Hearthrow airport. He was admitted & later reached his London home after 15 days. That's how we got to know of the seriousness.

That was his last trip to India.

I would call & enquire about his welfare. He would be in low life state. Two months back, he suffered from dimensia. Then the whole universe was under lock down due to Carona Virus. Just two day back April 14, which happens to be our Bengali New Year, I received the news from a source that Mr. PK Roy was one of the victim of Carona Virus & during his treatment, he could not take it anymore. He passed away that evening around 7.30 pm taking his last breath.

It was actually end of an era, end of that generation. He was 85...his birthday was on April 8 which was the time he would celebrate every year in Lucknow & always would catch his flight to London two days later. It was his routine every year. The whole thing seems to be a mystery. What is the status of that house if I ask... the answer would be difficult. My only concern is that the Heritage House should not go to the wrong hands. All Mighty... Please save that house in whatever way you can...

Arise and Awake!

Shreshtha Sengupta

It was 12 January, 1863 when a mighty lion was born in this sacred land of Bharata.
His one glance made men and women fearless!
His one roar made thousands cry for renunciation!
Many call him the '*Unconscious Father of India*'.
You call him *Swami Vivekananda*.
I call him Shiva, the Absolute.

कोटि-भानुकर-दीप्त-सिंहमहो कटि-तट-कौपिनवन्तम् ।
अभीरभीर्हुङ्कार-नादित-दिङ्मुख-प्रचण्ड-ताण्डव-नृत्यम् ॥

(Brilliant with the rays of a million suns, the lion among men, who has nothing but a loin cloth to wear. Who is dancing the violent dance of Siva, the quarters reverberate with the cry of "fear not, fear not!")

-Sharat Chandra Chatterjee (a direct disciple of Swami Vivekananda)

We have all heard of an orange clad Sannyasin, who had become the '**man of the hour**' after his famous speech in the Parliament of Religions.

Now, this man urged us all to realise that *we are all one with 'God'*!
What did he really mean by this?

Can people who identify as 'non-believers' or atheists realise God?

Now there is a very common misconception that a person is said to be spiritual iff he chants the name of God, day and night. Surely, the one who chants the name of God with all his heart and soul will definitely attain God one day. But what about people like you and me?

Some of you think that you simply don't have the intellect to understand metaphysics; while some you are rather confused by multitudes of dogmas, rituals and religions in this world while the rest hardly put any effort in understanding God and end up labelling their ignorance as atheism.

It was this man Vivekananda who had once said-

"The old religion says that an atheist is the one who doesn't believe in God, but the new religion says that the atheist is the one who doesn't believe in himself."

Vivekananda's spirituality was about discovering the divinity within. His religion spoke of serving the biggest God on earth, the human beings. To him life itself is religion. Be it your work in a farm or in a multinational company, all modes of work and all paths of struggles lead us to God. To toil is to pray. To him there is no difference between a beggar on the road and the God in the heaven, thus to serve a man is to serve the Almighty.

To pray at a temple, church or mosque alone doesn't qualify as worship. Any form of science,

art, work is therefore a form of worship. Whatever knowledge we gain every moment helps us to rise from a 'lower truth' to 'higher truth' and these paths of realisation are broadly classified into four i.e. *Bhakti, Karma, Raja and Jnana Yoga*.

Now an ordinary person like you and me, generally comes across these words often while listening to Mahabharata. All these paths of realisation were revealed to the Great Arjuna by Vasudeva Krishna via the '**Gita**'.

But such terms often confuse us! Although we have heard about these Yogas somewhere, most of us don't get the complete essence of these terms.

I will try to explain in brief what Vivekananda has to say about **Karma Yoga** in a simple and lucid manner through a real-life example.

When a child is 15, he is told that he will definitely be at peace once he completes his matriculation exam. But to his utter surprise, as soon as he turns 18, a realisation strikes him that it looks rather impossible to come out this wheel of endless duty and work. Sadly, it seems like this peace doesn't come to him until death.

Vivekananda points out that the goal behind any kind of '**Karma**' or work of any type or magnitude is, "**Freedom**". A saint feels oppressed with his bondage with the world and therefore seeks this freedom by trying to attain enlightenment. On the other hand, a robber steals in order to get this same freedom from poverty. Consciously and unconsciously every particle in this universe wants to march towards freedom. But how can this vicious cycle of constant duty give us freedom? It only seems to bring us endless pain and misery. Now here comes the concept of attachment and non-attachment. The very moment I attach my 'expectation of attaining good marks' to my purpose of reading a particular book, I end up inviting misery and an unknown fear of failure, an unknown fear of not being able to solve a question in the exam brings me an unnecessary amount of anxiety and distress. As a result, the very purpose of reading the book gets defeated. Thus, any kind of work performed which is motivated by any kind of selfish desire is bound to bring worries. The '**secret of work**' or 'Karma Yoga' is to work without any desire or attachment. One must perform a duty with complete non-attachment. Now Swamiji is absolutely right when he says that practising non-attachment is extremely difficult but certainly not impossible. When the idea of doing good without any external motive becomes a part of a human, he or she is said to be a 'Karma Yogi'.

Our first duty towards performing our respective duties perfectly is to have infinite faith in ourselves. This was Vivekananda's greatest message to all, that we are all potentially divine. All the power is already within us! This effulgent prince of the sages, the leader of the men proclaimed to the masses- God sits in the temple of every human body, identify this divinity and march forward without any fear, for fear is death and strength is life! Sharing one of my favourite poems by this legend which he had written for The Maharaja of Khetri, Rajputana. May Swamiji bless you all with immense strength and faith, my dear readers!

HOLD ON YET A WHILE, BRAVE HEART!

If the sun by the cloud is hidden a bit,
If the welkin shows but gloom,
Still hold on yet a while, brave heart,
The victory is sure to come.

No winter was but summer came behind,
Each hollow crests the wave,
They push each other in light and shade;
Be steady then and brave.

The duties of life are sore indeed,
And its pleasures fleeting, vain,
The goal so shadowy seems and dim,
Yet plod on through the dark, brave heart,
With all thy might and main.

Not a work will be lost, no struggle vain,
Though hopes be blighted, powers gone;
Of thy loins shall come the heirs to all,
Then hold on yet a while, brave soul,

No good is e'er undone.
Though the good and the wise in life are few,
Yet theirs are the reins to lead,
The masses know but late the worth;

Heed none and gently guide.
With thee are those who see afar,
With thee is the Lord of might,
All blessings pour on thee, great soul,
To thee may all come right!

– Swami Vivekananda



References:

1. Complete Works of Swami Vivekananda (Volume 1- Volume 9)
2. Lectures of Swami Sarvapriyananda (Spiritual Minister-Vedanta Society, New York)

Niyati Kumar Sarkar

ছেঁড়া গেঞ্জিটাকে সেনাই করে

তার ওপর ঢলঢলে ফতুয়া পরে সবাই কে নিয়ে ঠাকুর দেখতে যাওয়া লোকটাকে
বাবা বলে।

এক কৌটো গোবিন্দভোগ চাল আর সামান্য ঘি বাঁচিয়ে রেখে পুজোর মধ্যে একদিন পোলাও রান্না করা
মহিলাকে

মা বলে।

বন্ধুর জন্মদিনে পাওয়া চকোলেট টাকে লুকিয়ে সালোয়ার কামিজের গুড়নায়
ভায়ের জন্য বেঁধে আনা মেয়েটাকে দিদি বলে।

কাঠি আইসক্রিম টা অর্ধেক গলিয়ে ফেলে হাতে নিয়ে দিদির জন্য এক ছুটে মাঠ পেরিয়ে ছুটতে থাকা
ছেলেটাকে

ভাই বলে।

ফুলে ওঠা নতুন তাঁতের শাড়ি পরে দুটো ছোট ছেলে মেয়ের হাত ধরে বেরোনো বাতে পছন্দ বৃদ্ধাকে
ঠাকুমা বলে।

ডিজাইনার পাঞ্জাবি পরে অঞ্জলি দিতে দিতে পাশের বাড়ির নতুন শাড়ি পরা মেয়েটাকে কলেজ পড়ুয়া
ছেলেটির আড়চোখে দেখা টাকে ভালোলাগা বলে।

টরন্টো দুবাই থেকে ফিরে অষ্টমীর রাতে সবাই মিলে একজোট হয়ে স্কচের আসরে পান্ডার
ইলেকট্রিশিয়ান হাবু কে নিমন্ত্রণ করাকে ছোটবেলার বন্ধুত্ব বলে।

শিল্পীর হাতে ছ মাসের মেহনতে বানানো দুর্গাঠাকুর টিকে নাড়ি ছিন্ন করে বিক্রি করে সেই টাকায়
অনাথ অসহায় পথ শিশুদের জন্য জামাকাপড় কেনাটাকে

মানবিকতা বলে।

সপ্তমীর সকালে বউ ছেলে নিয়ে টানা গাড়ি করে গ্রামের বাড়ির পুজোতে হাজির হয়ে কাকা জ্যাঠাদের
প্রণাম করে আশির্বাদ নেওয়া মানুষগুলোকে পরিবার বলে।

বিশ্বের সবথেকে মনোরম আরামদায়ক জায়গা ছেড়ে এ কদিন বিবাহিত মহিলারা যে বাড়িটাতে স্বর্গ
মনে করে সেই বাড়িটাকে

বাপের বাড়ি বলে।

আর এই চিত্রকল্প গুলোকে একসঙ্গে সাজিয়ে নিলে যেটা তৈরি হয় বাঙালির তাকে এককথায়
দুর্গাপুজো বলে ।।।

With Best Compliments from



SRI TUNGA TRANSPORT
SHIMOGA, KARNATAKA

With Best Compliments from



Pawan Kumar

+91 9812246470



D.M. ENTERPRISES

TUNGALOY INDIA PVT. LTD.

Shayam Colony, Hissar Road, Near Hissar Bye Pass Chowk,
Rohtak-124001 (Haryana)

Email: dmenterprises8@gmail.com

With Best Compliments From

Steelbird
INTERNATIONAL

UNO MINDA
NK MINDA GROUP
THINK. INSPIRE. FLOURISH

SPARK MINDA
ASHOK MINDA GROUP
Powered by Passion

ARB
BEARINGS
ISO/ITS 16949-2009 Co.

**Arihant Auto Trading,
Biratnagar, Nepal**

With Best Compliments From



**GAURAV AUTO INDUSTRIES
BAWANA, DELHI**

With Best Compliment From



Rohit Mishra

TECHNOMECH ASSOCIATES

Opposite Bhagwati Education Centre, Near Gurudev Palace,
Shop No.: 167/4, Sharda Nagar, Kanpur-208025, Uttar Pradesh
M.: +91 9838999948, Email: technomech.associates@gmail.com

With Best Compliments From



Avanthi Warehousing Services

With Best Compliments From



**TIM INSURANCE SURVEYORS
& LOSS ASSESSORS PVT. LTD.**

9871970923, 011-45058555

Email : tarit@timgroup.in

With Best Compliment From



DEEPAK GARG

Director | 8802120888

SAFETY FIRST TRADEX PVT. LTD.

Correspondence Add.: B-176, Sec. 71, Noida-201307
Email: deepakgarg74@yahoo.com, safetyfirsttradex@gmail.com
Ph.: 0120-4152765, 9311150267

With Best Compliments from



Sree Venkatadri Transport Co., (R)

Fleet Owners & Transport Contractors

1st Floor, Laxmi Janardhan Complex, B.M. Road, Hassan 573201
Tel.: 08172-267104, 266362, 267105, Email: svt_hsn@yahoo.com

Mangalore Branch:

Shop No. 39, APMC Building, Baikampady, Mangalore-575010,
Tel.: 0874-2407007, 99005 57033

Bangalore Branch:

No. B-136, 2nd Floor, 3rd Main Yeshwanthpur Industrial Area, DDUTTL,
Bangalore 560022, Tel.: 99012 46789, 9910246790

With Best Compliment From



AJAY GUPTA

CLASSIC TOOLS

**CARBIDE INSERTS, CUTTER BODIES, INDEXABLE &
SOLID CARBIDE TOOLS, HSS DRILLING & MILLING**

3C-58 BP, N.I.T. Faridabad

M.: 9818111568, Email: ajaygupta@classictools.com

GST No.: 06AGRPG7357B1ZC

Authorised Distributors for:

**ADDISON, TOTEM, TUNGALOY, ITM, HOUGHTON,
STERLING GRINDING WHEELS**

With Best Compliment From

NTF



NTF (INDIA) PRIVATE LIMITED

49, Sector 3, IMT Manesar, Gurgaon - 122050 (Haryana), INDIA
Phone: +91 - 124 - 4840445 thru 61, Fax: +91 - 124 - 484062
E-Mail : info@ntfindia.net Website: www.ntfindia.com

With Best Compliment From



GAURAV VASHISHTA

SAGAA INDUSTRIAL PRODUCTS

Plot No. 64, S.M.I.E Phase-1, 20/2, Mathura Road,
Near Hundai Showroom YMCA Faridabad, Office: 0219-4109528
M.: 9971552002, Email: technosales.sip@gmail.com

*With Best
Compliment From*

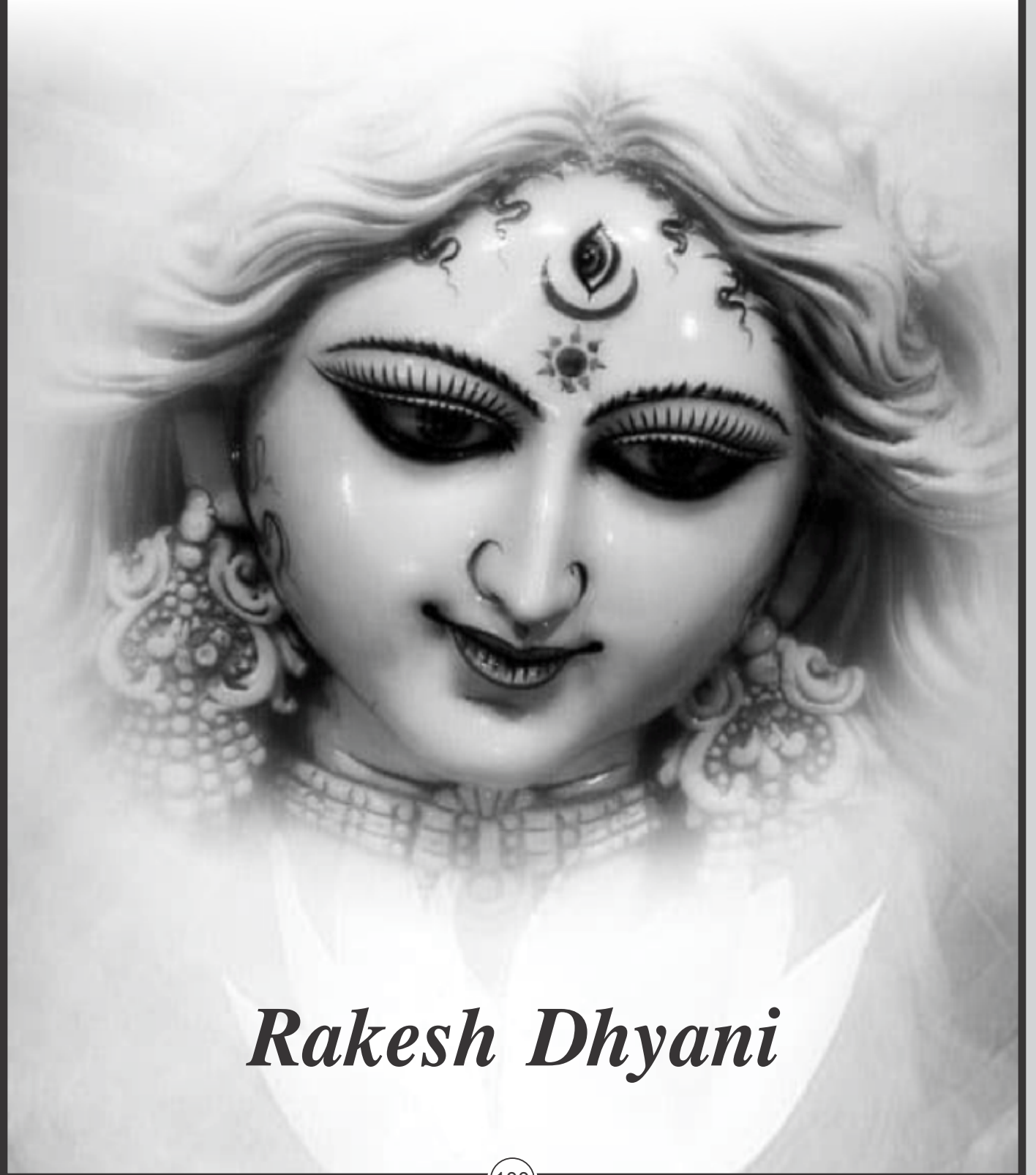

Rakesh Dhyani

With Best Compliment From



SANJEEV ENTERPRISES

Office: B-285, 1st Floor, Sangam Vihar, New Delhi-110080

Phone: 011-26043371, M.: 9811663988

Email: sanjeev.enterprises@hotmail.com

With Best Compliment From



SRI AMARE GOWDA & CO.
RAICHUR

With Best Compliment From



**Rakshitha Roadlines
Gadag**

With Best Compliment From



**Rajkumar Transport
Tumkur**

With Best Compliment From

Shahnawaz Nazari
9620628143, 08352-241909



SANGAMESHWAR TRANSPORT
H&T CONTRACTOR

C/O. SELEOT TRANSPORT CO.

Indira Auto Nagar, Station Back Road, Bijapur-02
Email: sangameshwartransport@gmail.com

With Best Compliment From



**Vanshika Security
Services (Regd.)**

*Specialist in Industries, Building,
Hotels & Office Security*

Head Off: A84, 2nd Floor, Sector-35 Noida (U.P.)
Branch Off: Pk-22, Sector-122 Noida (U.P.)
Branch Off: J-2 Bishanpura Sector 58 Noida (U.P.)
Email: vanshikasec.001@yahoo.in

With Best Compliments from

- SAHOO TRANSPORT
- ROUT TRANSPORT
- SAIRAM AGENCIES
- TARINI AGENCY
- RIDHISIDHI ENTERPRISES
- NATRAJ TRANSPORT
- SURESH KUMAR AGARWAL
- MAHAVIR TRANSPORT
- GANPAT RAM JAIN
- NIHAR ENTERPRISES
- SHREE JAGANNATH COOPERATIVE SOCIETY LTD
- JASODA ROAD LINES
- MAMATA MARKETING COOPERATIVE SOCIETY LTD
- MAA MAJHIGHARIANI TRANSPORT & CO
- E.P. POULOSE
- SUBHAM SALES
- MAA UTTARAYANI MULTIPURPOSE COOP SOC LTD
- MAHAVIR SERVICE COOP SOC LTD
- M.J. ROAD LINES
- RBC TRADING, KATHMANDU, NEPAL

With Best Compliments from



AN ISO 9001:2015 Certified Company

KRISHNA BULDESTATES PRIVATE LIMITED
Building Trust at Every Level Since 1954

Krishna Buldestates (KBE), a leading construction company based in New Delhi and having projects in Delhi, NCR, Punjab, Haryana, Rajasthan and other states and developing and delivering educational, institutional, residential, commercial projects having more than 14 million Sq. Ft.

KBE is well equipped to harness their vast experience in the entire gamut of construction activities acquired over more than 15 years.

Large real Estates enterprises such as DLF, India Bulls Real Estate, Birla Estate, Hero Reality, Jaypee, Godrej, Central Park II, AIPL, Triune, Suncity, Adani, NSL Infratech, Finton Homes, Ryan International Schools, Omaxe, Vatika, M3M, Monnet Group besides others have shown faith in KBE's ability to complete a project both within cost and required time while ensuring quality stays paramount.

KBE has been entrusted with landmark projects which shall redefine the NCR Skyline and ignite a new era of quality developments.

230 Experienced Engineers
90+ Projects Completed
14 Millions Sq. Ft + Area under Construction

253, Okhla Industrial Estate, Phase III, New Delhi – 110 020

www.kbe.co.in

+91 11 4601 9800, 9801



Subhanjali Chakravorty (Tiya)

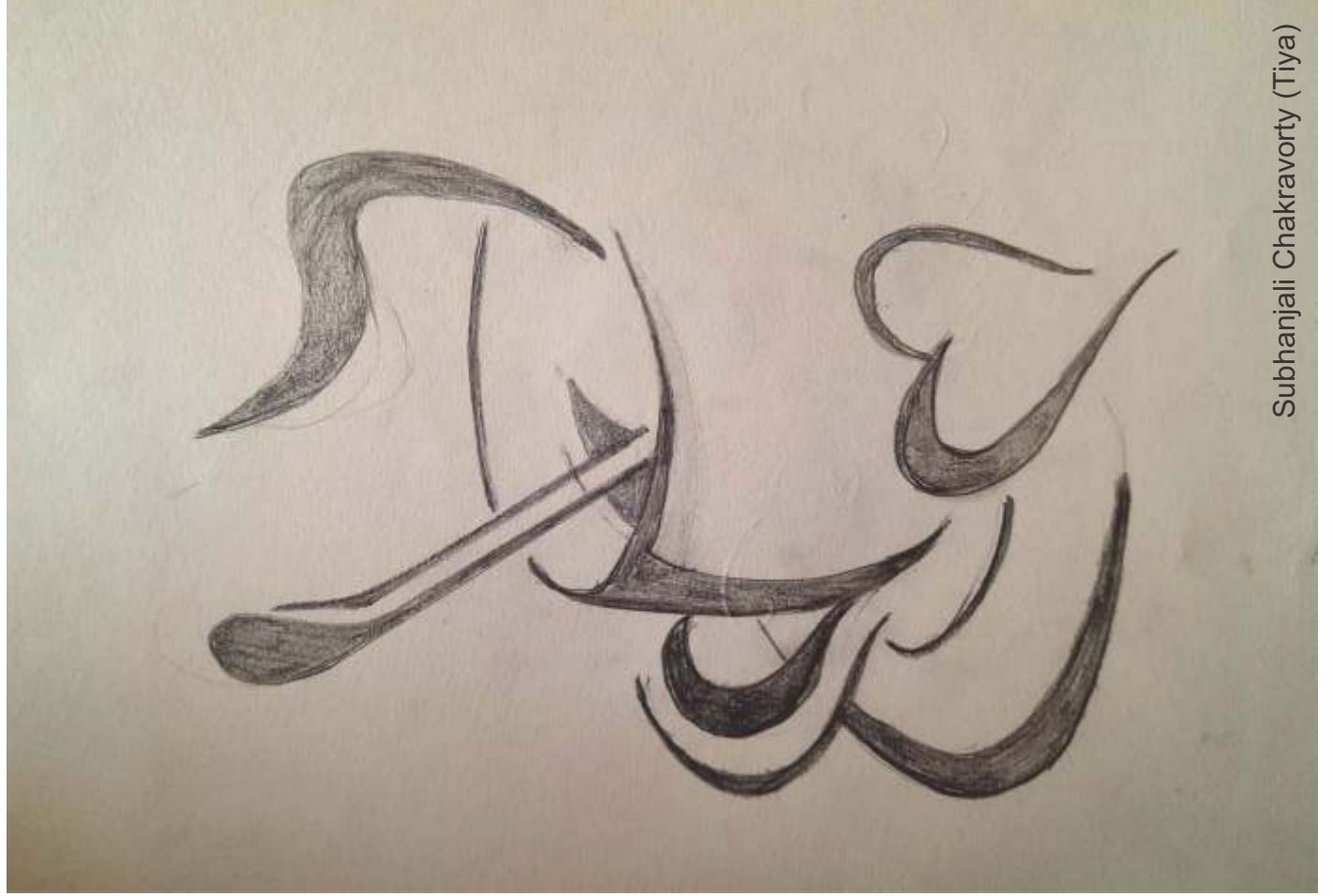

Subhanjali Chakravorty (Tiya)



Subhanjali Chakravorty (Tiya)



Subhanjali Chakravorty (Tiya)

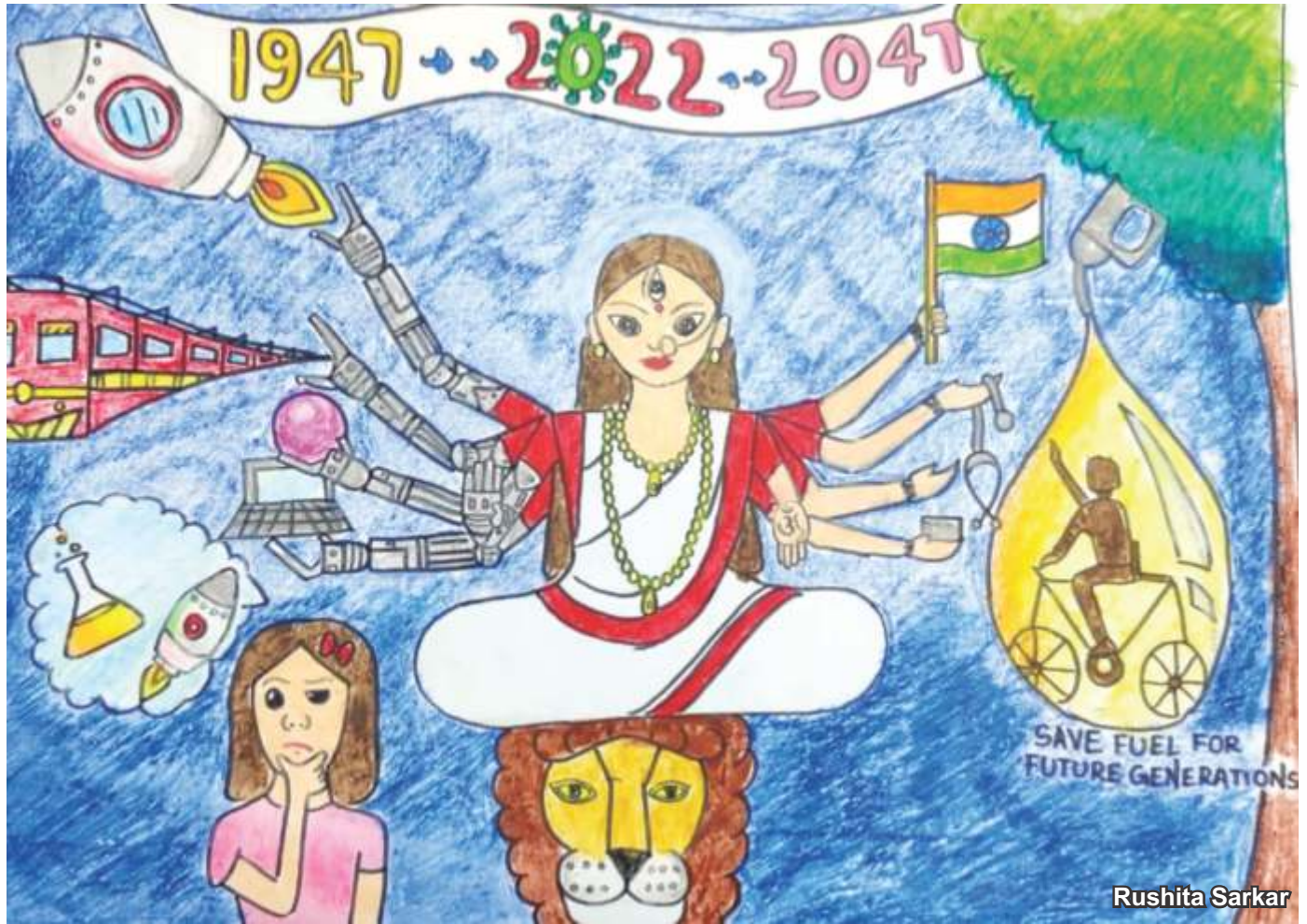

Rushita Sarkar



Malobika Roy



Malobika Roy

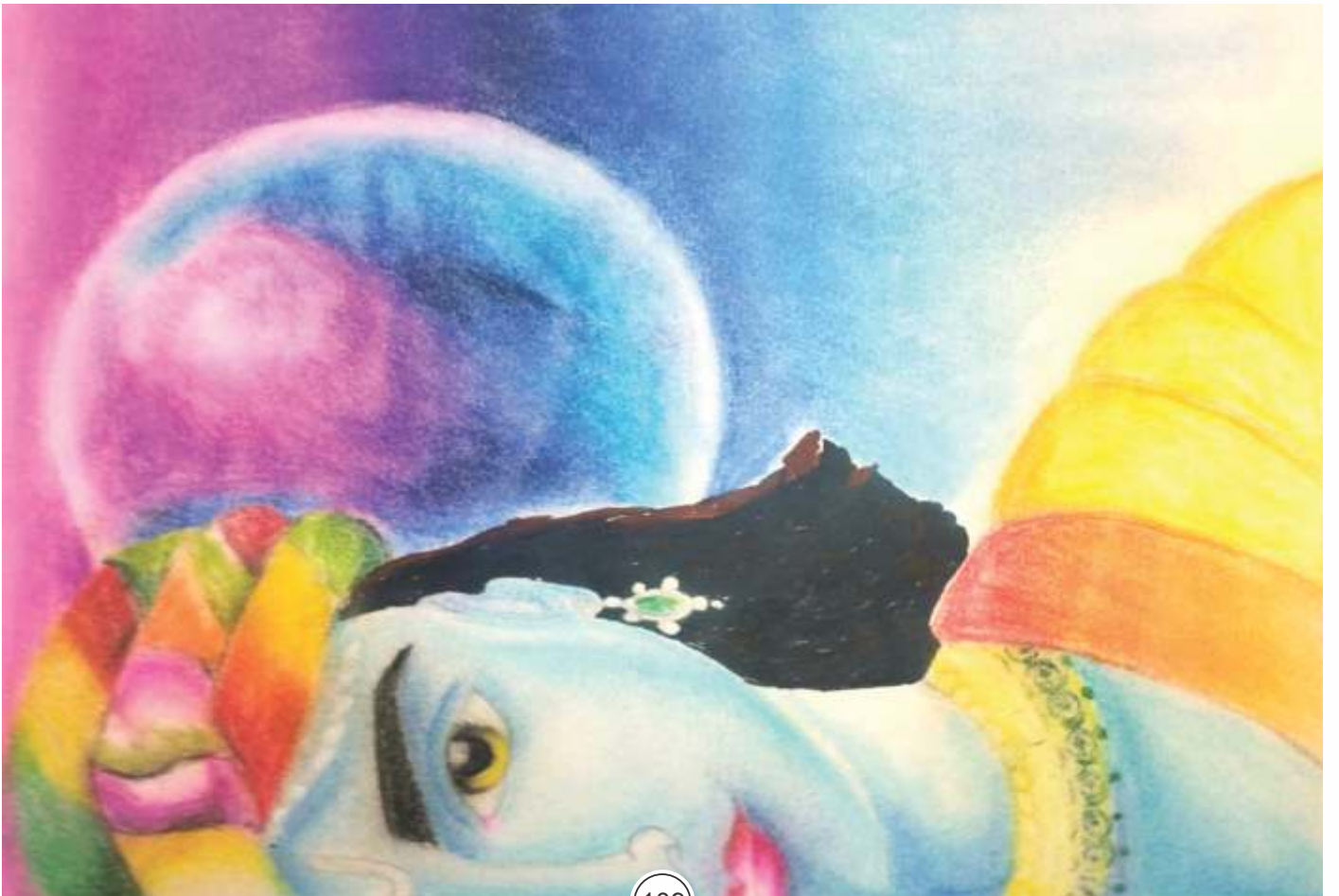

With Best Compliments from



SAARTHI AIRWAYS

With Best Compliment From



CLEARFAST

The Complete Solution
An ISO 9001:2008 Company

Clearfast Air Cargo Agencies Pvt. Ltd.

Clearing | Forwarding | Shipping | Warehousing | Transport

DPT Unit - 622, DLF Prime Tower, Okhla Industrial Area Phase-1,
New Delhi - 110020, T: +91 11 49078800 - 20 (20 Line) M: +91 98186 81928
E-mail : arun.kathuria@clearfast.com Web.: www.clearfast.com

Air Cargo (Mumbai)

Tel : 022 - 28253931, Fax : 022 - 28253931

Pune

Tel : 020 - 46760137, Fax : 020 - 46760137

Moradabad

Tel : 0591 - 2494977, Mob : +91 - 9837081077

Nhava Sheva

Tel : 022-27242458, 27240601, 27241067, 27877356,27877360
Fax : 022-27240598

Head Office : B2073 - 2076, Oberoi Garden Estates,
Saki Vihar Road, Chandivali, Andheri (East), Mumbai- 400 072
Tel : 022 40996666 (100 Lines) Fax : 022 40996600 / 48

With Best Compliment From



Precision Machines & Equipments (P) Ltd.
Heavy Fabrication / Special Machining

No. 9A, M.G. Road, NSC Bose Nagar, Poothapedu, Porur, Chennai-116
Tel.: 044-24767272, 24768281, F.: +91-044-24768292
Email: pmelpmts@gmail.com

Unit II: No. F23, 8th Main Road, II Cross Street, Sipcot Industrial Park,
Irungattukottai, Sriperumbudur-602105, Phone: 044-27156007

Unit III: No. A 40(a), Sipcot Industrial Park, Oragadam,
Sriperumbudur-602105, Email: pmelunit3@gmail.com



Web: muthuvelayundham.t.m.v@pmlindia.com | Web.: www.pmelindia.com

With Best Compliments From



DR. GERA

With Best Compliments From



Sri Sai Gramotham Samiti

*With Best
Compliment from*



M/S SHIVAM SALES

Ground Floor 23/14/2 Village Matiala
Uttam Nagar West, West Delhi-110059

Media Coverage & Activities (Social Work, Picnic, Sports) by Purbapalli Durgabari Samiti for Durgotsav 2021-22





PP-JPC Football Tournament Champions

After a hiatus of three years, the Joint Puja Committee organized its' 2nd Football Tournament on a cool Autumnal evening, on the 27th of August 2022.

As always PurbapalliDurgabari Samiti decided to participate in it with much enthusiasm and vigour. A team of 8 players were formed in April 2022, and the group trained sincerely and regularly for 4 months, straight. Not surprisingly, all the commitment, effort, and hard work paid off when the team won the tournament, beating 3 other teams convincingly!

PP's campaign begin with a thumping 5-0 victory over Pataudi Road, followed by 1-0 and 2-0 victories in the group stages.

It was only in the finals, where PP conceded their first goal against Bangiya Parishad, from a free kick. However, Purbapalli managed to claim a comfortable victory resulting from goals scored by Abhik and Sagnik, thereby clinching the trophy.

Each and every member of the team had a critical role to play and the triumph is a result of everyone's collective efforts.

Below is the squad that was chosen to participate:-

Goalkeeper – Anjan Ganguly

Defenders – Pallab Roy(Vice-Captain), Atrijit Das, Nilanjan Roy

Midfield – Sagnik Das (Captain), Saptarshi Mondal

Attack – Abhik Das, Proneet Banerjee



Purbapalli Durgabari Samiti Social Work During 2022

Purbapalli Durgabari Samiti a organisation with a high Social and Cultural values, always tried to give back to the community, take part in social causes. In last few years, members of Purbapalli engaged themselves in various philanthropic activities.

In January 2022, on the occasion of Makar Sankranti and Lohri we have visited the NGO called The Earth Saviours Foundation, on behalf of each precious member of Purbapalli. We wanted to convey our care for them though some goodies, there was an overwhelmed responses. Our members' generosity had helped to arrange the large quantity of essential dry rations and some woollen cloths. Purbapalli Social Responsibility team visited the shelter home at Bandhwari village, Gurgaon and handed over the materials for the fellow humans who are not so privileged. Many of them are abandoned, had special needs, were being abused, or had difficulty expressing their thoughts. However, when they saw us, they were so delighted that they stayed with us the entire time we were in the shelter.

Few of the glimpses during visit at shelter home:



DELEX CARGO INDIA PVT LTD - A DP WORLD COMPANY - OVERVIEW



Bulk's Network

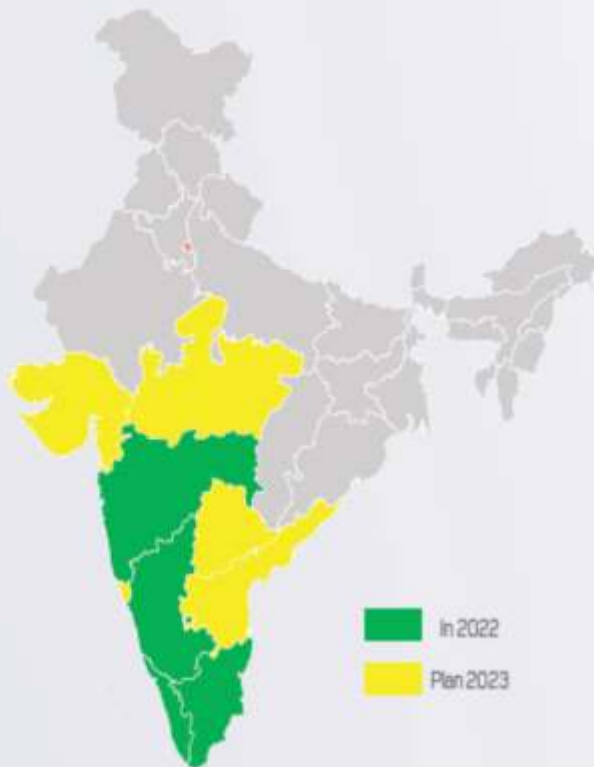

Bulk Service Portfolio

- Storage and Handling at Godown
- Rake Handling
- Secondary Transportation
- Primary Transportation

Karnataka – 18 Districts	Guberga, Yadgri, Bjjapur, Raichur, Belgaum, Hubli, Bellary, Haveri, Davengere, Chitradurga, Shimoga, Udipi, Mangalore, Hassan, Tumkur, Mandya, Bangalore, Hospet
Tamil Nadu – 8 Districts	Chennai, Kancheepuram, Anyalur, Thiruvalur, Trichy, Tanjavur, Vrindhaachem & Mundambakam
Maharashtra – 4 Districts	Aurangabad, Jaina, Nashik and Ahmednager
Kerala	Payyampur (Kannur) - FCI

DELEX CARGO INDIA PVT LTD – MAJOR CUSTOMERS



Fertilizers



Cement



Food grains





IT'S YOUR LIFE.
LIVE IT LARGE.

A BILLION DREAMS. ONE LARGE TEAM.

#InItToWinIt

Give a missed call to
73290 73290 and get a
chance to win exciting prizes.*

*T&C apply. Visit www.royalstagfan.com for details.